

CAKE AND COCKHORSE

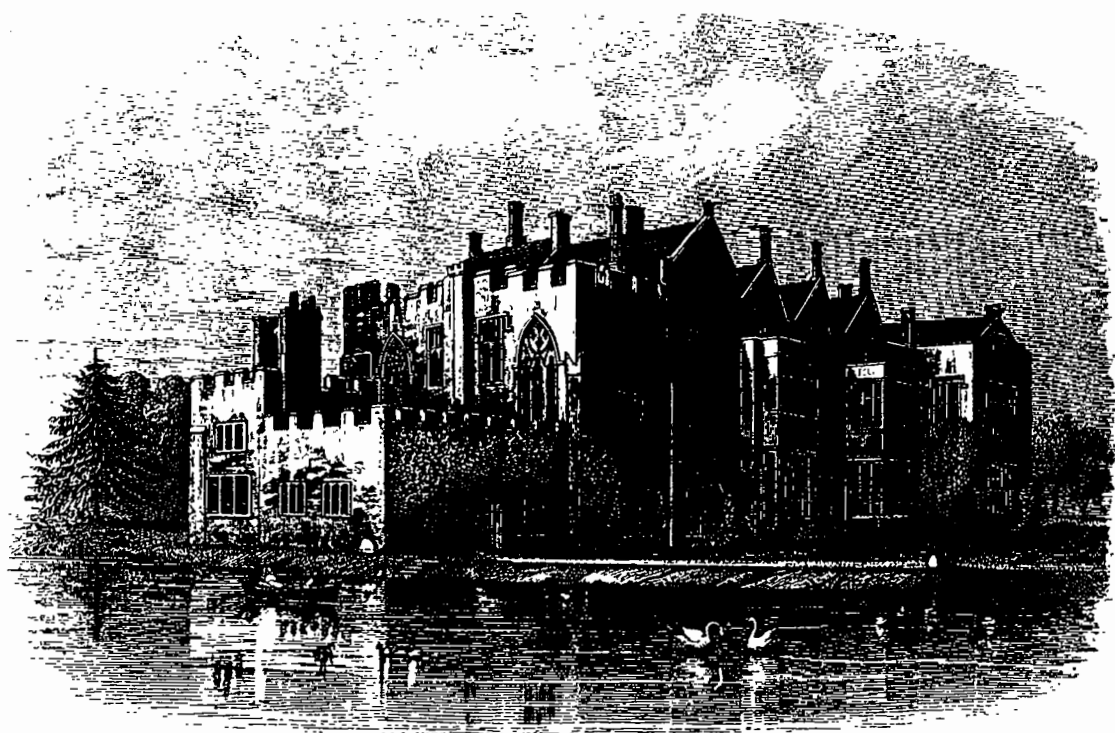

Banbury Historical Society

Autumn 1968

2s.6d.

BANBURY HISTORICAL SOCIETY

President: The Rt. Hon. Lord Saye and Sele, O.B.E., M.C., D.L.

Chairman: G. Fothergill, M.A. 102 Bath Road, Banbury

Hon. Secretary:
J.S.W. Gibson, F.S.G.,
Humber House,
Bloxham,
Banbury
(Tel: Bloxham 332)

Hon. Asst. Treasurer:
Dr. G.E. Gardam,
11 Denbigh Close,
Broughton Road,
Banbury
(Tel: Banbury 2841)

Hon. Treasurer:
A.W. Pain, A.L.A.,
c/o Borough Library,
Marlborough Road,
Banbury
(Tel: Banbury 2282)

Hon. Editor "Cake & Cockhorse"
B.S. Trinder, 90 Bretch Hill, Banbury

Hon. Research Adviser
E.R.C. Brinkworth, M.A., F.R. Hist.S.

Hon. Archaeological Adviser
J.H. Fearon, B.Sc.

Committee Members
R.K. Bigwood, J.F. Carter, T. Loveday

• • • • •

The Society was founded in 1957 to encourage interest in the history of the town of Banbury and neighbouring parts of Oxfordshire, Northamptonshire and Warwickshire.

The Magazine "Cake & Cockhorse" is issued to members four times a year. This includes illustrated articles based on original local historical research, as well as recording the Society's activities. Publications include "Old Banbury - a short popular history" by E.R.C. Brinkworth (2nd edition), "New Light on Banbury's Crosses", "Roman Banburyshire" and "Banbury's Poor in 1850", all 3/6d, and a pamphlet "History of Banbury Cross", 6d. A Christmas card has been a popular annual production.

The Society also publishes an annual records volume. These have included "Oxfordshire Clock-makers, 1400-1850"; "South Newington Churchwardens' Accounts, 1513-1684"; "Banbury Marriage Register, 1558-1837" (3 parts) and "Baptism and Burial Register, 1558-1653". "A Victorian M.P. and his Constituents: The Correspondence of H.W. Tancred, 1841-1859", "Banbury Politics, 1830-1880", "Banbury Inventories, 1590-1650, and Wills, 1621-1650", and the second part of the Banbury Baptism and Burial Register, 1653-1723, are well advanced.

Meetings are held during the autumn and winter, normally at 7.30 p.m. in the Conservative Club. Talks on general and local archaeological, historical and architectural subjects are given by invited lecturers. In the summer, excursions to local country houses and churches are arranged. Archaeological excavations and special exhibitions are arranged from time to time.

Membership of the Society is open to all, no proposer or seconded being needed. The annual subscription is 40/-, including the annual records volume, or 20/- if this is excluded. Junior membership is 5/-.

Application forms can be obtained from the Hon. Secretary or the Hon. Treasurer.

CAKE AND COCKHORSE

The magazine of the Banbury Historical Society. Issued to members four times a year.
Volume Four. Number One. Autumn, 1968.

NEWS		Society Activities	2
ARCHITECTURAL	J. H. Fearon	Primitive Sundials or Mass Clocks	3
MINUTAE	P. S. Spokes	The Heraldry of the Chimney-piece in Queen Anne's Room, Broughton Castle	13
EPILOGUE	J. S. W. Gibson	The Original Cake Shop	16

On January 9th 1838 that most public-spirited of nineteenth century Banburians, Edward Cobb, presented the committee of the town mechanics' institute with a glass case containing minerals for a museum. This was the beginning of the town museum, which has since endured a chequered history, and which entered a new phase with the recent opening of the new display (see page 2)

Most people in Banbury still think of the museum as the crowded assortment of curiosities kept, until a few years ago, in the room next to the reference library. Here the most unlikely objects were to be found in close proximity. The exquisite medieval alabaster figure from the former Banbury parish church kept company with the skeleton of a cat found beneath floor boards at the Reindeer Inn. Fragments of German bombs of World War II were to be found along with the Parish Vestry Book, an invaluable source to historians of the 18th century, but one which needs hours of attention before it becomes interesting. In the circumstances perhaps we should be grateful that the collection, gold and dross, survived at all, rather than be critical of the standards of display, but certainly the museum did little to arouse interest in local history, and it was difficult to recommend visitors to go there.

On the acquisition of the Globe Room panels the old museum room was needed as a book store. The reopening of the museum in its new and much larger room was delayed by the determination of the Librarian and the former Libraries and Museum Committee that exhibits should be properly displayed. Without museum staff this seemed an insuperable problem until contact was made with Mr. Raymond Singleton, the Director of the Department of Museum Studies, University of Leicester, who was able to arrange for his students to work on Banbury's collection as a 'project'. A tremendous amount of repair and restoration was thus done to the collection. Finally, during a week's visit to Banbury, six of the students erected the display they had already planned - all at virtually no cost to the Borough. The new display is a vast improvement on anything previously on view in Banbury, and should prove a source of interest to tourists as well as a useful aid for local teachers. School children will at last be able to see just what Banbury plush looked like, for example. And many, adults included, will be astonished that such a beautiful fabric was made locally.

No one would expect a town of Banbury's limited size to have a museum with a full range of ancillary services, but the appointment of a full time qualified curator is essential if the museum is to be of any real benefit to the local community. The display should only be the tip of the museum iceberg. Behind it should be facilities for the identification of objects brought in by the public, an organisation for arranging special displays on particular topics for schools, factories, churches and other bodies, and a source of energy and curiosity to seek objects to fill gaps in the collection. Several times during discussion on the future of Banbury's museum, the museum at Ludlow, visited by 30,000 people a year, has been mentioned. This museum is not well housed. It contains, apart from its fossil collections, no exhibits of national significance. Yet it is rarely without visitors, and school children in particular find it a place of absorbing interest which they love to revisit. The museum thrives only because it has an enthusiastic curator, who can breathe life into the most unpromising subjects. If Banbury's museum is to flourish then such a person must be found to inspire it.

We understand our museum is already attracting a daily average of 40 visitors, despite the fact that it is only open 14 hours a week. Unless a Curator is appointed and is able to vary the exhibits from time to time, the display must inevitably lose its freshness and vitality; interest will wane and in the words of Mr. Singleton, "this will become just one more museum which should never have been reopened".

Our Cover: is taken from an engraving of Broughton Castle published by G. Walford, May 1860, and printed in Johnson's "History of Banbury".

SOCIETY NEWS AND ACTIVITIESAutumn Programme

All meetings are held at 7.30 p.m. on Thursdays at Banbury Conservative Club (next to Martins Bank, High Street).

26th September. Heralds and Heraldry, 1968. (illustrated). John Brooke-Little, Richmond Herald and President of the Heraldry Society. Members will recall Mr. Brooke-Little's previous talk to the Society some years ago, and will look forward to a stimulating evening.

24th October. Oxfordshire Ironstone Mining over Fifty Years. (illustrated). John Scott Young. Mr. Young was for many years manager of the Oxfordshire Ironstone Company which ceased operation last year.

21st November. Excavation at Shakenoak. (Illustrated). Anthony Hands. This Romano-British site near Witney was overlain by Anglo-Saxon occupation.

Dates for 1969: 30th January, 20th February, 20th March, 29th April (at Deddington).

The Victorian Church

A series of six lectures entitled "The Victorian Church and after" will be given by the Society's Hon. Research Adviser, E.R.C. Brinkworth, M.A., B.Litt., at the Borough Library, Marlborough Road, Banbury, on Monday evenings at 7.30 p.m. beginning on September 30th. The fee for the course will be 12/6 and each lecture will be illustrated with slides. People today are greatly interested in all things Victorian, yet the Victorian church is much neglected. This is strange, for its story is a fascinating one; full of event, crisis and convulsion; of rich, intriguing characters; of exploring thought and incredible obscurantism in unexpected places. The story is important too, for Church and State were still so close-knit that it is impossible to understand the one without the other, and the story provides the immediate background without which it is impossible to understand the present. Dr. Brinkworth's knowledge of local church history is unrivalled, and there will be frequent local references during the series.

Annual General Meeting

The A.G.M. was held on 22nd June at Wroxton College, by kind invitation of Dean Loyd Haberley. In spite of torrential rain over sixty members attended. At the meeting, briskly chaired by Dr. H.G. Judge, Dr. C.F.C. Beeson was elected a Vice-President; afterwards members were able to see round the house. We extend our thanks to Dean and Mrs. Haberley for their welcome.

Banbury Museum

Banbury Museum was reopened on 19th July after a closure of several years. Guests of honour at the official reception by the Mayor were Mr. Raymond Singleton, Director of the Department of Museum Studies, University of Leicester, and five of the six students who were responsible for the display and the work that had gone before. The Historical Society was represented by the Chairman, Mr. G.J. Fothergill.

The new display is housed on the second floor of the Public Library building in Marlborough Road, close to the Globe Room panels.

Opening hours are:- Monday, Wednesday, Thursday and Friday: 3.00 - 5.00; Saturday: 9.30 - 12.30, 2.00 - 5.00. Tuesday: closed. Entrance free.

The "Globe Room ceiling" at Shoppenhangers Manor

It is pleasing to report that in addition to the Globe Room panels, on view at Banbury Museum, the copy of the ceiling from the room, at Shoppenhangers Manor near Maidenhead, can now also be seen by the public. In our Globe Room issue (Vol. II No. 10. p. 174. November 1964) we published a short report on the ceiling, confirming that it was made up of casts of parts of the Globe Room ceiling from the Reindeer Inn, Banbury. When the ceiling was inspected in August 1964 the owner of the house had recently died, and the future of the building was uncertain. It has become part of the new Esso Motor Hotel, and the ceiling can be seen in what is now the restaurant. There are many other features of architectural and historical interest at Shoppenhangers, and a visit is to be recommended.

Surprisingly large numbers of our old parish churches still bear the remains of primitive sundials on their walls (see Figure 1). The existence of these strange markings has been known and discussed for the last 200 years or so but it is only recently that their true use as time-markers has been suspected. Old writings describe them variously as "mason's marks", "consecration marks" or "protractors", and there is much speculation in Victorian literature about their purpose. However in the middle of the first World War, Dom Ethelbert Horne, of Buckfast Abbey, published a scholarly little book⁽¹⁾ in which their use as primitive sundials or "mass clocks" was explained. A few years later Mr. A. R. Green⁽²⁾ elaborated the theory and filled in some of the detail, while in 1938 Mr. T. W. Cole^(3,4) suggested that their use was to mark the times of the principal medieval services. Surprisingly, since that time no further notice appears to have been taken of them, which is a great tragedy, as many of them are fast disappearing with the ravages of weather (Figure 2) if not at the hands of the restorer (Figure 3).

What do they look like?

All mass clocks or scratch dials have one feature in common - a central hole which held the style or gnomon. These holes are either in the mortar between stones or else in the stones themselves. The styles were probably of metal, and indeed remains of both wrought iron and white metal styles have been found. Others may have been of wood, and there are also records of wooden remains in one or two holes.



Figure 1. Circular dial on the south wall of Helmdon Church, Northants.



Figure 2. Dial in the last stages of decay. Kings Sutton, Northants.



Figure 3. Partial obliteration of dial by restoration of stonework with mortar. Duns Tew, Oxon.

The engravings round the hole exist in a great variety of forms and some of the more common are illustrated in Figure 4. The simplest, and probably the oldest (Figure 4a), have only three lines, in addition to a vertical noon-line which may be the edge of a stone. Later, they became more and more elaborate with the rays enclosed in half circles (Figure 4c), circles (Figure 4d) or finishing in holes (Figures 4f, g, h), and even extending upwards to positions where a shadow could never fall (Figure 4e).

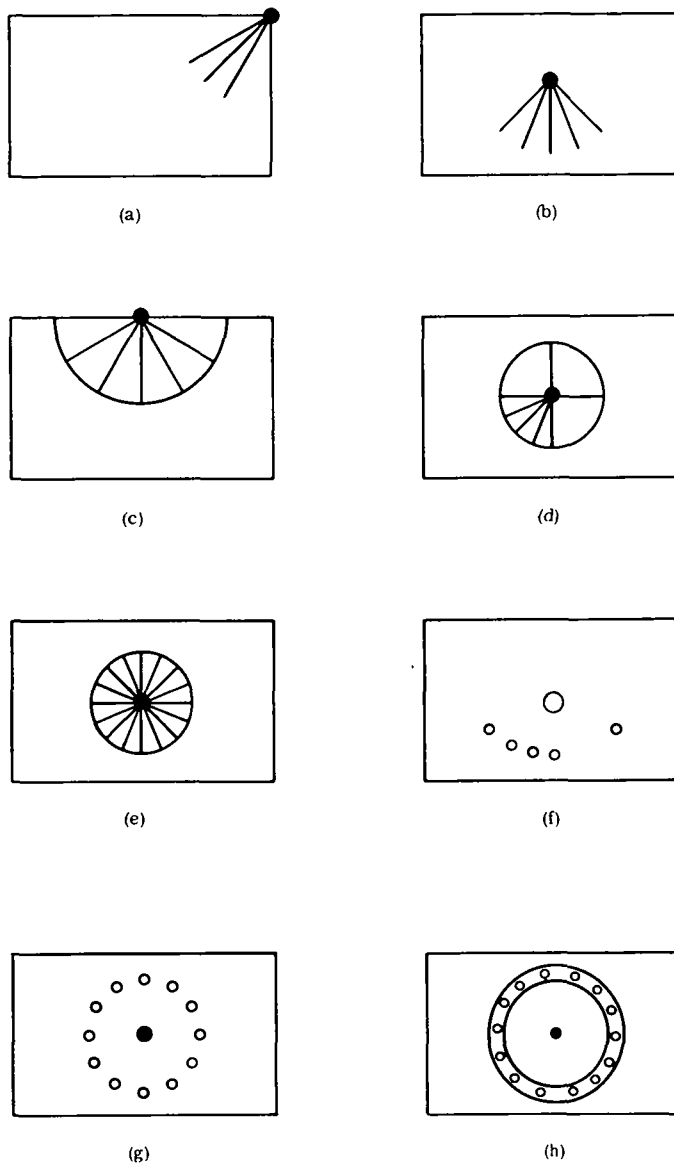

Figure 4. Diagrams of some common designs of scratch dials.



Figure 5. Inverted dial, resulting from disturbance of stones during restoration. Tackley, Oxon.



Figure 6. Three ray dial at Croughton, Northants.

Where are they found?

Scratch dials which have not been disturbed are invariably on the South wall of the church. The most common position is on the wall of the porch but they are often found near the priest's door, on buttresses, in quoin stones or in window frames. Some are to be seen inside porches on the original south wall, indicating their existence before the porch was built. Incidentally this simple fact was quoted by some Victorian writers as convincing proof that the markings could not be sun-clocks, as the sun was not able to penetrate inside the porch.

Their height above ground level averages about 5 feet (i. e. about eye level) but may as low as 3 feet or as high as 10 feet.

Dials may occasionally be seen on other walls, but this is a result of restoration work, as also is the upside down dial (Figure 5). The large number of dials reported in inverted positions after restoration may well indicate some form of superstition amongst the builders who carried out the work.

A rough estimate, based on fairly extensive sampling by the author, indicates that over half the churches in Oxfordshire, Warwickshire and Northamptonshire still have recognisable dials, and a few published lists for other parts of the country, notably Hampshire and Somerset, suggest that this figure may be typical for the country as a whole. If no dials are found on old churches, the reason is almost certainly one of the following:

- (a) Restoration or rebuilding has destroyed them.
- (b) Weathering has eroded them.
- (c) The church is too large (only smaller churches in general are found to have dials, and I am indebted to Dr. C.F.C. Beeson of the Antiquarian Horological Society for the suggestion that larger churches, with several clergy, probably relied on hour glasses rather than dials for time marking).
- (d) They are obscured by lichen or other vegetation.

What was their purpose?

No positive answer can be given to this question in the absence of written evidence; but the authorities already quoted have concluded that their use was either to mark the principal church services or else to serve as a general time indicator for the village. Neither explanation can be considered wholly satisfactory.

Mr. T. W. Cole⁽³⁾ suggests that their purpose was to record the times for the three principal "offices": terce (9 a. m.), sext (midday) and none (3 p. m.) but this theory is difficult to uphold in view of the many dials which have no indication of time after midday (c. f. Figure 6).

Another significant factor, pointed out by Horne, is that the dial is usually placed on the South wall in the position which is first reached by persons using the path to the church. This suggests to him that it was intended more for use by people outside the churchyard rather than by the incumbent or his assistants.

In these days of precise time-recording it is not easy to visualise the rhythm of our agricultural forebears, where lives were ruled by the sun and weather rather than the clock. In times when people worked in the fields from sunrise to sunset, and stopped to eat when the sun was overhead, there was little need of exact knowledge of time. It is perhaps tempting to think of the leader of a gang of reapers sending the boy down to the church to find out the time, but even today the agricultural labourer rarely needs to consult his watch and there would be even less need then.

On the other hand it is equally unsatisfactory to imagine the parson relying on his sundial and the uncertain chance of sun at the right time to tell him when to start his services. These doubts are amplified by the construction of the dials, which take no account of seasonal variations and thus are inaccurate for a large part of the year.

We must await the results of further research for a final explanation of the purpose of these clocks. The balance of probability seems to favour their use as service-indicators, but the exact manner in which they were used is still far from clear.

How were they constructed?

Sundials were known to the Romans and also to the Saxons. The latter, however, found four daytime "tides" sufficient for their purpose and a number of Saxon dials, dividing the day into four, are still in existence. They can be distinguished from mass dials by the cross-lines on the rays (Figure 7).

As no mass clocks have been identified on pre-Conquest churches, it is a fairly safe assumption that the scratch dial was imported by the Normans (a search for similar dials on churches in Northern France should provide evidence, but no records have come to light of such an investigation). The makers would certainly be able to determine midday by observing the varying length of a shadow on a horizontal surface as this technique has been known from antiquity. This would enable them to establish a noon line, in one of two ways. With a solid style already set in the vertical stone, its shadow could be marked and cut at the exact time. Alternatively, if the noon line had already been cut as a vertical line, the style could then be bent until it matched the noon line. As dials with (Figure 8) and without (Figure 9) vertical rays have been observed, it seems probable that both systems were used. Horizontal lines would give sunrise and sunset positions and the remainder of the construction was probably carried out by trial and error. As small dials are often found near to larger ones, it is likely that experiments were sometimes carried out before the main dial was cut.

Obviously, whatever method of construction was used, the dials could never be precision instruments. The true sundial with its gnomon set at an angle corresponding to the degree of latitude did not appear until many years later. The proliferation of primitive dials, nevertheless, is a good indication that they played some important role in the life of the parish, which is still far from clear.

There is a great deal of scope for further investigation to establish the exact function of these dials, and a start could be made by setting up a plaster cast of a typical dial and recording

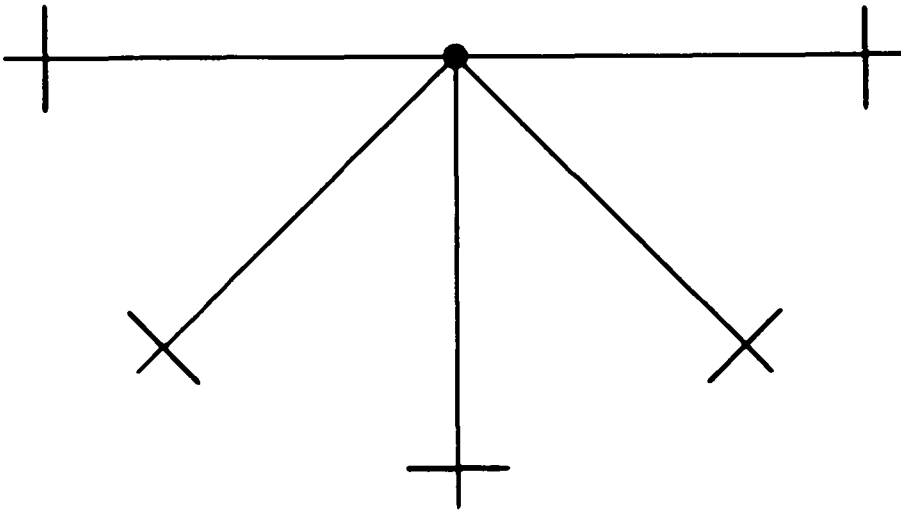

Figure 7. Typical Anglo-Saxon dial, dividing daylight into four "tides".

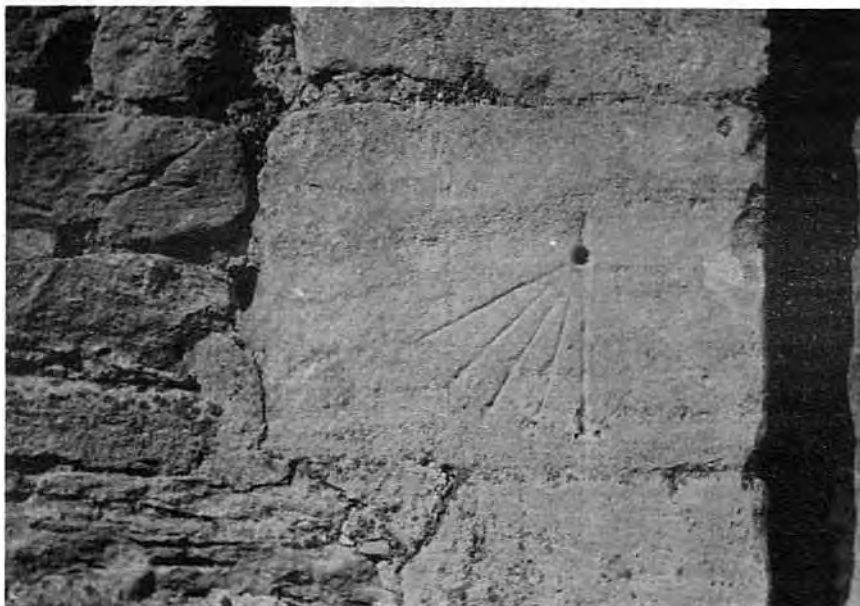

Figure 8. Dial with vertical noon line (Brackley St. Peter, Northants.).



Figure 9. Dial without vertical noon line (Preston Capes, Northants.).

its behaviour at various hours and seasons, (see, for example, Figure 10). However, a far more urgent task is to record the dials that are in danger of obliteration, by time or by careless repair work to the fabric. This is a task that can be commended to anyone with an interest in village church history. Photographs and dimensioned sketches (or pencilled "rubbings") are adequate to preserve a record that may be of great value in the years ahead.

J.H. Fearon.

References

1. Dom Ethelbert Horne. "Primitive Sundials or Scratch Dials" Taunton. The Wessex Press. 1917.
2. A.R. Green. "Sundials" London. S.P.C.K., 1926.
3. T.W. Cole. "Origin and Use of Church Scratch Dials" London. The Hill Bookshop, 1938.
4. T.W. Cole. "Scratch Dials and Medieval Church Sundials" London. Author, 1938.

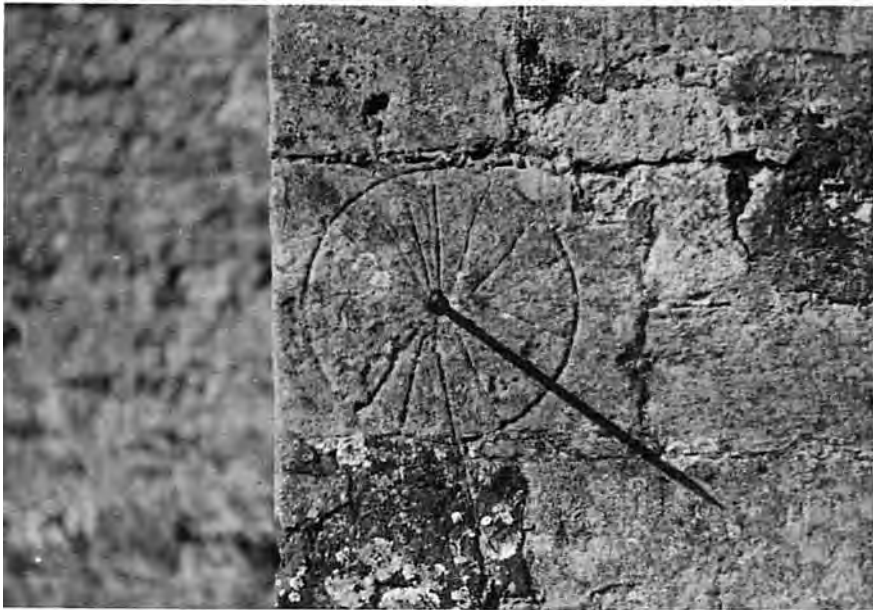

Figure 10. Shadow of pencil set in the hole of a dial at 4.45 p.m. BST, 14th August.

C.F. Grubb's Work table: a correction

Miss E. Watt of Aynho points out that the Art Journal description of Mr. Grubb's table quoted on p. 233 of our last issue errs in describing the leaves on the pedestal of the table as "dock leaves". They are in fact acanthus leaves, first used by the Greeks for Corinthian capitals, and afterwards adopted for silver work.

Recently published reports of the Northamptonshire Archives Committee and the Oxfordshire County Records Committee include a number of references to documents relating to the Banbury area.

Northamptonshire: The outstanding accession to the Record Office during the past year has been the deposit on loan by Lady Hesketh of the manuscripts of the Northamptonshire historian George Baker which for many years had been hidden away among the collections of the eccentric Sir Thomas Phillipps of Middle Hill, later of Thirlestaine House, Cheltenham. The collection contains much original material of great interest, but of special importance to local historians will be a volume of the Rector of Middleton Cheney's historical notes on his own parish and neighbourhood of which only a small part could be included in Baker's published work. The Rector of Aynho has deposited a number of valuable records including a book of the agricultural by-laws issued by the manor court (1723-45), accounts of the fieldsmen (1734-92), overseers' accounts from 1694, and a book of constables' accounts covering 1679 to 1709. Other accessions of interest to Society members include a geographical study of Eydon of 1928 deposited by Mr. S. J. Tyrrell, some Chacombe deeds of 1833-90, documents relating to the Brackley Feoffees, and maps and stations plans of railways in the Rugby division of Northamptonshire, dating from 1870.

Oxfordshire: Accessions include Inclosure Commissioners' minutes for Sibford Gower, 1773-4 and South Newington, 1794-5; copies of Inclosure maps of Claydon, 1776, and Horley and Hornton, 1849; draft conveyances of property of the Lampet family in Hook Norton, Banbury and Wigginton; title deeds of the Gough family of Souldern, 17th and 18th c.; the original manuscript of 'Shoemaker's Window', from Mr. Arthur Cheney; and undoubtedly most important of all, a magnificent collection of some 800 estate maps relating to Oxfordshire, Warwickshire and Northamptonshire, from Mr. H. C. Stilgoe.

The Local Editor of the Oxfordshire Victoria County History reports that the Bloxham Hundred volume is at an advanced proof stage of production; and editorial work continues on the Banbury Hundred volume.

Publications

Messrs. David and Charles have recently re-printed that classic of canal literature E. Temple Thurston's "The Flower of Gloster", an account of a journey in a narrow boat on the waterways of the south Midlands first published in 1911. It includes descriptions of Somerton, Banbury and Cropredy, as well as the famous account of the legging of the boat through Sapperton Tunnel on the Thames and Severn Canal. The re-print costs 35s. Colin Bell of the Banbury Social Survey published the results of a religious census taken in the town on 31st March 1968 under the title "Church attendance in a small town" in "New Society", 30th May 1968. An article by Pamela Horn, "Farmers' Defence Associations in Oxfordshire - 1872-74" appears in Vol. 1 No. 1 of the new journal "History Studies" published by Pergamon Press. S. J. W. Bromet of the Old Rectory, Upper Boddington, has published "Memoirs concerning parsons and the parsonage of Boddington" by Dr. E. Maynard. This is a transcript of an original in the parish chest written by Dr. Maynard (1654-1740). The 28 page illustrated booklet costs 10s., the profits going towards church funds.



Figure 11. The chimneypiece in Queen Anne's Room, Broughton Castle, showing the Danvers crest on the left and the Nevill arms on the right.

Richard Fiennes had livery of his father's lands (which Margaret his mother had held in dower) in 1541 and was aged 34 in 1554 and unmarried. His father, Edward, *de jure* Lord Saye and Sele, died in 1528 and was buried at Broughton. Edward married in about 1518 Margaret the third of the six daughters of Sir John Danvers by his wife Anne ('The Lady of Dauntsey'). Sir John Danvers died in 1514 and was buried at Dauntsey, Wilts. Margaret Fiennes married as her second husband Sir Thomas Nevill of Holt upon the Hill, Leicestershire; he was executor of Anne Danvers ('The Lady of Dauntsey') whose will was proved in 1539. Margaret was living in 1541. Sir Thomas Nevill was High Sheriff of Leicester in 1539 and died in 1569. Margaret's brother William Danvers of Culworth, Northants., (c. 1495-1544) had married in about 1522 Elizabeth Fiennes, sister of Edward, Lord Saye and Sele.

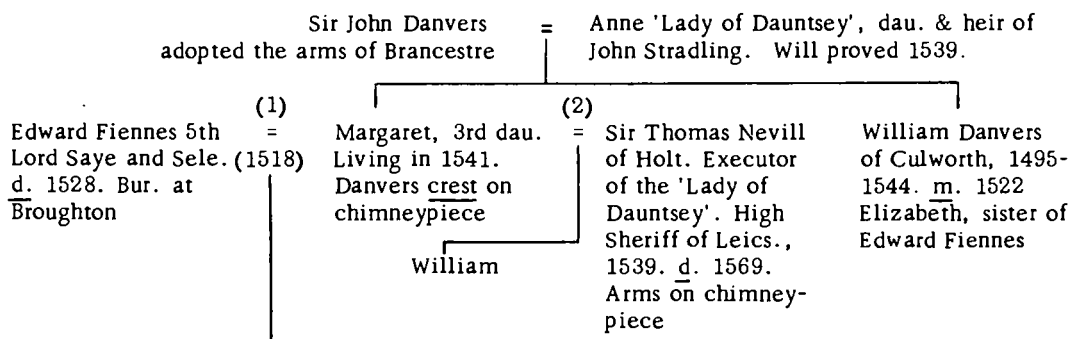

Richard Fiennes

b. 1520; succeeded as 6th Lord, 1528; for whom (?) John Chapman made chimneypiece at Broughton in 1554; m. 1556 Ursula Fermor; Sheriff of Oxon, 1567; d. 1573

Macnamara in his "Memorials of the Danvers Family" p. 327, says: "Some three or four years after the marriage of Edward Fiennes and Margaret Danvers (the parents of Richard with whom we are concerned) a great company of kindred and friends would assemble in the old hall at Broughton to witness the marriage of William Danvers and Elizabeth Fiennes. There, as host and hostess, were the young couple Edward Fiennes and his wife, sister of the bridegroom, and with them their new born heir Richard and his grandmother the 'Lady of Dauntsey'".

Anne Danvers, the 'Lady of Dauntsey', says in her will (1539), "To Richard Fynes (i.e. son of her daughter Margaret) I give my best bason and ewer of silver when he shall be 21". Richard was then aged 19.

Sir John Danvers, maternal grandfather of Richard Fiennes (aged 34 in 1554) adopted the arms of Brancestre (his great grandfather had married the heiress of Brancestre):

On a bend three martlets (or popinjays) vert. In Thomas Wall's Book of Crests (1530) the Danvers's crest is given as "a right hand open charnu the sleve gules the edge in grayled a martlet vert standing on the fyngers endes having an annelet gold in her mouth". And in the 1634 Visitation of Oxon, "A parrot vert in its mouth an annulet gold".

Thus Richard Fiennes when he commissioned (?) John Chapman, master mason to William Sharington of Lacock, to make the chimneypiece (Figure 11) in 1554, or thereabouts, was then unmarried and his mother Margaret Danvers had remarried Sir Thomas Nevill of Holt. However Richard did not put the Fiennes arms on his chimneypiece but put the crest (Figure 12) of his mother's family on the left in the place of honour and the arms (Figure 13) (a saltire with an annulet in the centre) of his stepfather (who had been the executor of his grandmother, the 'Lady of Dauntsey') on the righthand side. Had the chimneypiece been made after Richard's marriage



Figure 12. The martlet or 'parrot' of the Danvers crest.



Figure 13. The saltire of the Nevill arms.

with Ursula Fermor in about 1556 he would almost certainly have put his own (Fiennes) arms and those of his wife on it.⁽¹⁾

Thus it seems that the chimneypiece cannot be later than about 1555 which would fit in well with the rest of the work then going on at Broughton. Otherwise, on stylistic grounds, parts of the chimneypiece could be of a date later on in the century. But the Sharningtonian details (or those of his "architect" John Shute) as carried out by the mason John Chapman at Broughton in 1554 were very "modern" for the time and can be compared with similar work at Lacock by Sharnington in 1540-49. Dudley Castle (Hall built by the Duke of Northumberland under the direction of Sharnington), at Longleat for Sir John Thynne (d. 1580) in 1554 and at Sudeley for Thomas Lord Seymour in about 1548. It is still necessary to seek the personal relationships of Richard with such men as Edward Seymour, Duke of Somerset (beheaded 1552) Dudley, Duke of Northumberland (then aged 52), Sir William Sharnington (died 1553, aged 58), Sir Francis Bryan (courtier and diplomat, died 1550) and John Shute, the "architect", who died in 1563. John Chapman is mentioned as King's mason in accounts of 1541 and worked at Longleat up to 1567. He made the fireplace still to be seen at Bisham Abbey and a detailed comparison of this with the Broughton one remains to be made as well as a comparison with Sharnington's fireplace still in the gallery at Lacock. As a tentative suggestion, Richard may possibly have been in touch, before 1549, with Thomas, Lord Seymour of Sudeley⁽²⁾ (a man of his own age) who introduced him to the Sharnington group for whom Shute and Chapman are known to have worked.

The characteristic "Sharningtonian" details* consist of: a shelf, supported on consoles, under the windows and doorways with square heads and a classical entablature, carried on consoles at either side; these are to be found at Broughton. Writing about Sharnington, W. Douglas Simpson says (Arch. Jnl. CI, 124-5): "He was an active man of affairs and the experienced administrator, well able to handle the business side of a large building work. No doubt with his keen and cultured interest in the new Italianate movement, he would exert no small influence, particularly in the substitution of Renaissance for Gothic details. Sharnington's patron was Thomas Seymour, Baron Seymour of Sudeley, for whom he carried out important building operations at Sudeley. Here also the characteristic "Sharningtonian" details may be seen. In building Longleat Sir John Thynne was in touch with Sharnington, to whom he applied for the use of the carver Chapman, who probably was responsible for the two splendid stone tables in the Italian style, still to be seen in Sharnington's tower at Lacock. Sharnington did not lend Chapman to Thynne, because the carver was then about to start for Dudley Castle, there to set up a chimneypiece which he had made at Lacock. Thus the architectural activities of this little group of men - of the noble patrons, Northumberland, Somerset and Sudeley; of their business managers, Thynne and Sharnington; of the carver Chapman and the architect Shute, whom Northumberland sent to Rome - all are linked together by documentary evidence, and all of them were pioneers in an energetic drive to oust Gothic altogether, and to establish Renaissance forms as well as detail".

To sum up: Assuming the crest on the chimneypiece is that of Danvers (which I do) then is it possible to say that no one else except John Chapman, under Sharnington's (and possibly Shute's) direction could have done such a work in 1554. Could Chapman have made it at Lacock and brought it to Broughton as he did in the case of the chimneypiece he made at Lacock and took to Dudley Castle?

P.S. Spokes.

* Archaeological Journal, CI, (1944) p. 120.

References

1. In the east window of the south aisle of Broughton church is armorial glass in the upper tracery showing the crest of a bird's head raxed gold, in its beak asure a gold ring. (Lamborn. Armoial Glass. Oxf. Dioc. 1949. p. 114.)
2. He was then aged about 40 and was beheaded in March 1549 having had a grant of Sudeley from Edward IV on 19th August 1547. Any work by him at Sudeley must presumably be confined to the period from August 1547 to January 1549 when he was arrested.

THE ORIGINAL CAKE SHOP

The last sorry chapter of a disgraceful tale is now ended, and nothing remains of Banbury's Original Cake Shop in Parsons Street. The Minister of Housing and Local Government supported his Inspector's view that the provisional building preservation order made on 8th April should not be confirmed, and accordingly demolition was rapidly completed by the development company. The Minister agreed "with the Inspector's view that the building ought to be preserved if that were at all feasible;" but noted "that the building had been partially demolished and that, as a result, it was open to the weather and therefore subject to increasing dilapidation. . . . He would not necessarily agree with the Inspector's view that any restoration would be inappropriate. However, from the evidence given at the inquiry by the owners, the County Council and the Borough Council it was clear that none of these would undertake the works of restoration" — nor was there "any evidence that anyone else would do so".

Lessons can be drawn from this demolition. An owner of an historic building will not necessarily keep it in good repair: evidence was given at the Inquiry that the Shop had apparently suffered many years of neglect by the former owner, resulting in severe decay to timbers. Powers to make preservation orders are useless if the will is not there; the local authorities involved were more anxious to avoid any possible short-term burden on the rates than to promote the undoubted long-term advantage to the town of the retention of such an obvious tourist attraction. Developers, for all their claims to try to preserve historic buildings they happen to acquire, will usually find it convenient and financially advantageous if their restoration is uneconomic or impossible; no great care was taken of the Shop before demolition started; once it had, in the few hours available the roof and windows received first attention — features at once the most attractive and whose removal would ensure the greatest deterioration from the weather.

Some present-day Banburians (and others), with an eye to their rates, profits or "progress", may rejoice at the Shop's disappearance; but we can be certain that Banburians of the future will compare its demolition with those of the original Cross, the Castle and the medieval Church — all expedient at the time.

J.S.W. Gibson.

The Bizzell family: an enquiry

Mr. J.L. Bizzell of 13, Beaufort House, Aylesford Square, London S.W. 1. has asked for the Society's assistance in tracing the existing members of the original Oxford Bizzell family. He writes: "I do know from the official Registrar's records that JOSEPH STANLEY, son of CHARLES and ELIZA BIZZELL, was born 14th May 1893 at Hornton. Charles, the father, was a police constable". Mr. Bizzell is anxious to know if Joseph Stanley Bizzell still lives in the district.

The activities and publications of some or all of the following bodies should interest readers:

- Arts Council of Banbury (Miss B.G. Rooke, Cornerstones, St. Mary's Road, Adderbury West, Banbury). Minimum 21/-.
- Banbury and District Civic Society (J. Barnden, Hon. Tr., c/o Barclays Bank Ltd., Bridge Street, Banbury). 10/6d.
- Banbury Art Society (Hon. Sec., 24 Bloxham Road, Banbury). 15/-.
- Banbury Geographical Association (B.E. Little, 2 Burlington Crescent, Banbury). 5/-.
- Bicester Local History Circle (Hon. Sec., Miss G.H. Dannatt, Lammas Cottage, Launton Road, Bicester, Oxon.). 5/-.
- Buckinghamshire Record Society (Hon. Sec., J.G. Jenkins, Twitchells End, Jordans, Bucks.). 42/-.
- Council for the Preservation of Rural England, Oxfordshire Branch (Mrs. J. Scott-Cockburn, North Oxon. Sub-Committee Membership Sec., Hornton Hall, Banbury). Minimum 5/-.
- Dugdale Society (published Warwickshire records) (Shakespeare's Birthplace, Stratford-upon-Avon). 42/-.
- Farthinghoe Historical Society (Hon. Sec., R.E.J. Lewis, Abbey Lodge, Farthinghoe, Nr. Brackley, Northants). 5/-.
- Heraldry Society (59 Gordon Square, London, W.C.1). 30/-; or to include "The Coat of Arms", 50/-.
- Historical Association (59a Kennington Park Road, London, S.E.11) (Oxford Branch: A.J.P. Puddephatt, 93 Old Road, Headington, Oxford). 20/-; or to include "History", 35/-.
- Northamptonshire Record Society (Delapré Abbey, Northampton). 21/-.
- Oxford Architectural and Historical Society (Ashmolean Museum, Oxford). 15/- or to include "Oxoniensia", 42/-.
- Oxford Preservation Trust (The Painted Room, 3 Cornmarket Street, Oxford). Minimum 5/-.
- Oxfordshire Record Society (Dr. W.O. Hassall, Hon. Sec., Bodleian Library, Oxford). 21/-.
- Shipston-on-Stour and District Local History Society (H.G. Parry, Hon. Sec., 8 Stratford Road, Shipston-on-Stour, Warw.). 7/6d.
- Warwickshire Local History Society (47 Newbold Terrace, Leamington Spa.). 10/-.
- Woodford Halse Historical Society (J.W. Anscomb, 7 Manor Road, Woodford Halse, Rugby, Warw.). 5/-.

"The Amateur Historian", published quarterly is available from the National Council of Social Service, 26 Bedford Square, London, W.C.1. - single copies, 3/6d; annual postal subscription, 15/-.

Printed by Express Litho Service, Oxford

for the Banbury Historical Society

All articles in this publication are strictly copyright.

