

CAKE & COCKHORSE

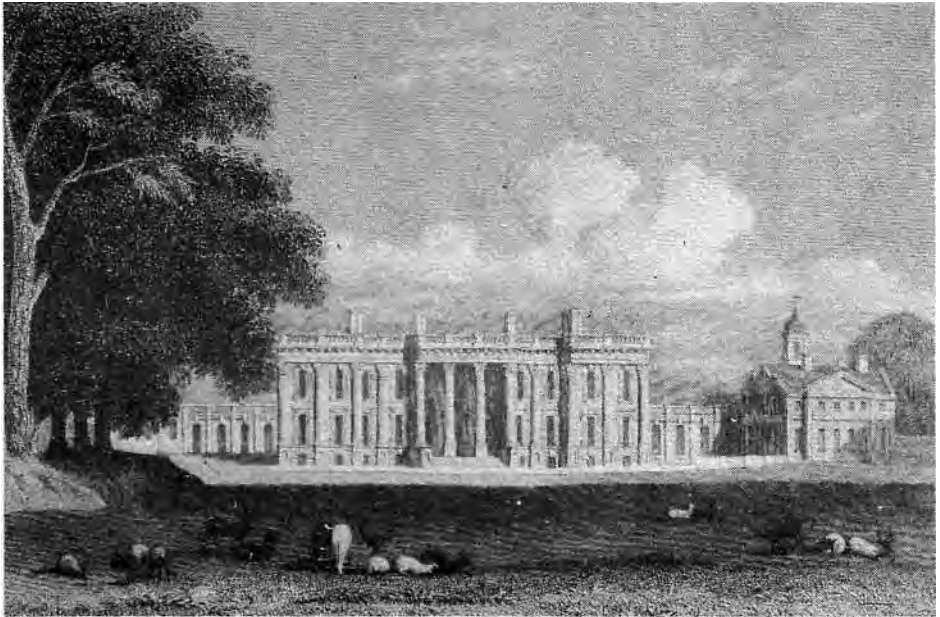

BANBURY HISTORICAL SOCIETY

AUTUMN 1977. PRICE 35p.
ISSN. 0522-0823

BANBURY HISTORICAL SOCIETY

President:

The Lord Saye and Sele

Chairman:

Alan Donaldson, 2 Church Close, Adderbury, Banbury.

Magazine Editor:

D.E.M. Fiennes, Woadmill Farm, Broughton, Banbury.

Hon. Secretary:

David Smith, LL.B.,
62 Bath Road,
Banbury.
(Tel: Banbury 52414)

Hon. Treasurer:

Mr G. de C. Parmiter,
The Halt,
Hanwell, Banbury.
(Tel. Wroxton St. Mary 545)

Hon. Membership Secretary:

Mrs Sarah Gosling, B.A., Dip. Archaeol.
Banbury Museum,
Marlborough Road.
(Tel: Banbury 2282)

Records Series Editor:

J.S.W. Gibson, F.S.A.,
11 Westgate,
Chichester PO19 3ET.
(Tel: Chichester 84048)

Hon. Research Adviser:

Dr E. R. C. Brinkworth,
43 Church View,
Banbury.

Hon. Archaeological Adviser:

J. H. Fearon, B.Sc.,
Fleece Cottage,
Bodicote, Banbury.

Committee Members:

Dr. E. Asser, Mr. J.B. Barbour, Miss C.G. Bloxham,
Mrs. G.W. Brinkworth, B.A., Mrs. N.M. Clifton, Miss F.M. Stanton

Details about the Society's activities and
publications can be found on the inside back cover

Our Front Cover is taken from a print of Heythrop House dated 1831.
Those who were at the AGM will recognize the unchanged front facade, not
yet enfolded in wings.

CAKE & COCKHORSE

The Magazine of the Banbury Historical Society. Issued three times a year.

Volume 7	Number 4	Autumn 1977
J. S. W. Gibson	A Century of Tavern-Keeping:- Part 1 The Stokes Family at the Unicorn and Three Tuns	103
Pamela Horn	Mrs Frances Ann Bowkett - A Banbury Schoolmistress at the Turn of the Century	116
Sarah Markham	Unpublished Notes on Heythrop House and Kirtlington Park	120
Book Reviews	The Egerton Family of Adstock in the County of Buckingham	121
	Civil Strife in the Midlands 1642-1651	122
	Railway History in Pictures: Chilterns and Cotswolds	123

It is no use snivelling about rising costs. As historians, we know that inflation has happened before. The new annual subscription of £4.50 for members who receive records volumes, and £3.00 for others is cheap compared with those of similar societies. Please let the treasurer have your 1978 subscription early, and please use the deed of covenant and bankers order form which is enclosed. Apart from the reserve for records volumes in preparation, the coffers are nearly empty.

Please also seek out new members; a membership form and a second deed of covenant form are enclosed with this issue of *Cake & Cockhorse*. An increase in membership from the present 300 to 400 should be an attainable target for 1978.

The main reason for our comparatively low subscription has been the cheapness of production of *Cake & Cockhorse*, made possible by the generosity of our out-going editor, Julian Barbour. He has made available his remarkable typewriter and his equally remarkable secretary to prepare the copy which is then printed direct without typesetting. That arrangement will continue. We are greatly indebted to Julian. Also we most warmly thank our out-going chairman John Roberts whose stint of office ended at the AGM. His bubbling enthusiasm for the Society will be missed.

It is in the nature of the world that chairmen and editors come and go. So too it seems with shops; Mawles the Banbury ironmongers are to close after more than three quarters of a century; MacFisheries after

twelve years. In the MacFisheries closure there is a lesson; until twelve years ago the building was the Talbot. The Talbot had lived as such for years. So it is right and proper that the main contribution to this issue of Cake and Cockhorse, from the indefatigable pen of Jeremy Gibson, tells the story of two pubs. The Unicorn still quenches thirsts as it did in the seventeenth century; the Three Tuns is now disguised as the Whately Hall Hotel. Who would care to moralise on the fact that even non-frequenters cling to churches and pubs as the symbols of social continuity?

But one must not forget the schools. It is a joy to know that Mrs Bowkett, who has taught so many Banburians, still lives among us. Now aged 102, she was appointed a head mistress in Banbury in 1898 and first taught as a student teacher in 1889. Read all about this magnificent woman of history in this issue.

D. E. M. F.

CALTHORPE MANOR

Earlier this year the committee of your Society wrote to the Cherwell District Council asking the Council to reject the application to demolish Calthorpe Manor, Danvers House, and Dashwood House, Banbury. Many others also made representations and permission was refused.

It is sad that recourse had to be had to government control. It is sad too that, given the law and planning regulations, our Banbury planning is no longer the concern exclusively of Banburians. There is now no body of Banbury people minding our future, so that Banbury may be made an ever more enriching place in which to live and work.

History began in the past. It continues into the future of which it is the foundation. History is concerned with how men have lived, and therefore with how they will live. We have helped to preserve Calthorpe Manor, part of our history from the 16th century. Preserved for what? It is easy to say no, when one has no responsibility for the "yes". It is easy to preach conservation, forgetting that the building to be conserved was once an effort of creation.

Should there not be a Society for the Future of Banbury, of which the Banbury Historical Society would properly be a foundation member?

D. E. M. F.

A CENTURY OF TAVERN-KEEPING: Part 1
THE STOKES FAMILY AT THE UNICORN AND THE THREE TUNS

Shortly after the restoration of Charles II, Parliament was faced with the need to finance their much impoverished King. To raise this money a new tax was introduced, based on the number of hearths in people's houses, a form of approximate income or wealth tax - the wealthier the man, the more rooms (and hearths) he would have in his house. Thus for occasional years early in that reign a record survives of all households, their occupiers and number of heated rooms. For Oxfordshire these years were 1662 and 1665.

In 1662 by far the highest assessed household in the town of Banbury, at eighteen hearths, was occupied by "Mrs. Stokes".¹ Three years later, described as "Joane Stokes", she was still, at sixteen hearths, the highest rated in the borough.² Although the names and locations of houses are not given in these returns, it now seems certain that this building must have been the Unicorn tavern. The inn still stands, tucked back in its courtyard, with Mr Wills its jovial landlord. Into the 18th century or even later the fine three-gabled range (recently so well restored by the Nationwide Building Society), facing the Market Place, was also part of the tavern.³

That Joan Stokes was later owner of the tavern is shown by her will, in 1677/8, when she left instructions for its disposal. Documentary evidence confirms precisely that the tax assessors were dealing with that part of the Market Place. What little earlier information there is points to Joan and her late husband William being its builders.

William Stokes was born in 1603.⁴ His father was Henry Stokes, described variously as a carrier and as a fishmonger, who died in 1628, when the family home was in Parsons Lane. This was left to the eldest son Nicholas, with provision of accommodation - "the parlour next the street" - for Henry's widow Dorothy. William was left £40, as was his younger brother Fulke "at the end of his apprenticeship", and his unmarried sister Dorothy. By the early 1630's William was married - his eldest child, also William, was baptised in June 1632. In all Joan and he had seven sons and three daughters, all of whom survived childhood (except probably the youngest).

In 1635 he was elected a tithingman - a responsible post and the first step towards membership of the Corporation.⁵ He occurs as a creditor, for 2s., of Jeremiah Abraham who died that year; and in 1639 he exhibited the inventory of one Susannah Devell or Denell.⁶

In March 1640/1 comes the first evidence of his occupation as an innkeeper, and with it of his standing and prosperity. So described, he entered into a bond with three others, and £500 as security, for paying the annual rent of £377 for three years on 209 acres of pasture in Walton, near Charlton in Northamptonshire.⁷ His three senior partners are interesting -

Robert Vivers, of a leading Banbury family who married into the local gentry, the Hawtyns of Calthorpe House, where he now lived;⁸ William Allen and Nathaniel Wheatley, both senior aldermen and former Mayors. Clearly Stokes moved in the right circles. It is no surprise to find him as witness to the will of another local man of some importance, Edward Edens, the town clerk, in November 1643; whilst his prosperity is shown by taxation records of 1642-3, when he was amongst the highest assessed in the borough.⁹

All premises selling liquor within the borough had to be licensed by the Corporation, and taverns, the distinctive name for wine-houses, were restricted to two in Banbury as in nearly all market-towns.¹⁰ It seems very probable that a man of the standing of William Stokes would already have been one of these tavern-keepers, and this is confirmed by a deed of August 1647, when he is described as a "vintner". The intervening years had seen the country, and Banbury in particular, plunged into Civil War. It was not until that ended that Stokes became a member of the Corporation, being elected a Chief Burgess in 1648. For the year 1648-9 he was appointed junior auditor.

The sieges of the castle during the war had caused great damage to much of the town. That most of Banbury's earliest and finest surviving buildings date from the late 1640s or the 1650s is no surprise. There must have been a great need for replacements, stimulated after 1648 by the supply of good building stone available from the demolished castle - even though traditional timber-framing was still popular, as in Edward Vivers' fine house in the High Street, which is dated 1650.

It is probable that the town's inns did not fare well during the war. The best-known was the Altarstone, of medieval origin. John Hall, its owner, was clearly fearful when he made his will¹¹ in April 1645; it was a time when the castle had survived one seige and work to make it more secure may well have been in progress. He made elaborate provision for his heirs "if it so be that my houses do not stand namely the Altarstone and the George . . . if the houses be pulled down." One substantial inn, probably the Three Swans in St. John's Street (South Bar), is described in an inventory of 1617, but in deeds later in the century it sounds of little consequence.¹² The Reindeer in Parsons Lane must also have been important in the 1630s, when the Globe Room was installed, and indeed was to remain so until at least the early 18th century.¹³ But evidently there was room for a new and large tavern to cater for changing needs.

There are two early pieces of positive evidence to the Unicorn's building and existence as a tavern: first, the date "1648" carved on the gates of the archway leading to the courtyard, still to be seen. This corresponds with the likely date of building, and there is no reason to doubt its authenticity and that it marks the opening of the tavern.¹⁴ The other is a trade token. As can be seen, it shows a figure of a unicorn and the lettering "AT THE VNICORNE", with, on the obverse, "IN BANBERY 1650" and



Illustration of a tavern token for the Unicorn (from Beesley's "History of Banbury", plate 26).

the initials W^SI. Previous commentators have speculated as to the owners of these initials. Milne¹⁵ suggested "W.S." might stand for William Sprigge, on no apparent basis except that he was a Banbury man whose initials fitted. Dr Beeson,¹⁶ with greater reason, suggested William Style, because a new wine licence was issued to Daniel Style in 1685. However, it is now clear that the initials in fact stood for William Stokes and his wife Joan or Joanna (the letters I and J were interchangeable).

So the Unicorn was built in 1648, and its landlord probably William Stokes in 1650 - so it is interesting to find that in August 1647 Stokes was buying "all that plot or piece of ground in Banbury in a street called Barkehill Streete, as the same heretofore was and is now divided and set out, upon part whereof lately a messuage was erected and stood; and also that barn and buildings belonging . . ." ¹⁷ In medieval times Barkhill appears particularly to have referred to the north side of the Market Place, but later it seems probable that this term also covered all the north-western part, alternatively known then as Cornmarket street and now as Cornhill, including the houses either side of the entrance to Parsons Lane.¹⁸ If that was the case the property that Stokes bought in 1647 very probably was the site of the present Unicorn Inn.

Only a few weeks after William Stokes had acquired his property in Barkhill, in September 1647 a family transaction took place when William Robins, a Banbury mercer, granted his younger brother Thomas Robins, another mercer, that "plot of ground in or near the Markett Place known as Lebarkehill, containing from east to west 105 ft. on the south side and in breadth from north to south 21 ft. on the greatest part whereof lately stood a messuage and other edifices . . . which were devastated and pulled down in the time of the late unnatural warre . . ." ¹⁹ If, as has been suggested, Barkhill included the houses on either side of Parsons Lane, then this description could refer to the property on the corner of that street, next to the Unicorn.²⁰ Here, as will be shown, Thomas Robins some time subsequently built the "Prebendal House" whose much-restored 17th century facade is such an attractive feature of Parsons Street.

In February 1651/2, as a Burgess, William Stokes lent £2.10s. towards the purchase of a new mace (it still survives). This was a large sum, only exceeded by the Mayor's loan and equalled by those of two of the aldermen - most Corporation members subscribed £2. Four years later, still a Burgess, he supported the then Mayer, Aholiab West, when he and a small party attempted to suppress the sheep market in Sheep Street, which the Corporation wanted moved elsewhere. A near-riot ensued; during this Stokes was hit on the head or hat by a stone. Depositions for

Simplified pedigree of the
STOKES and STYLE Families of Banbury

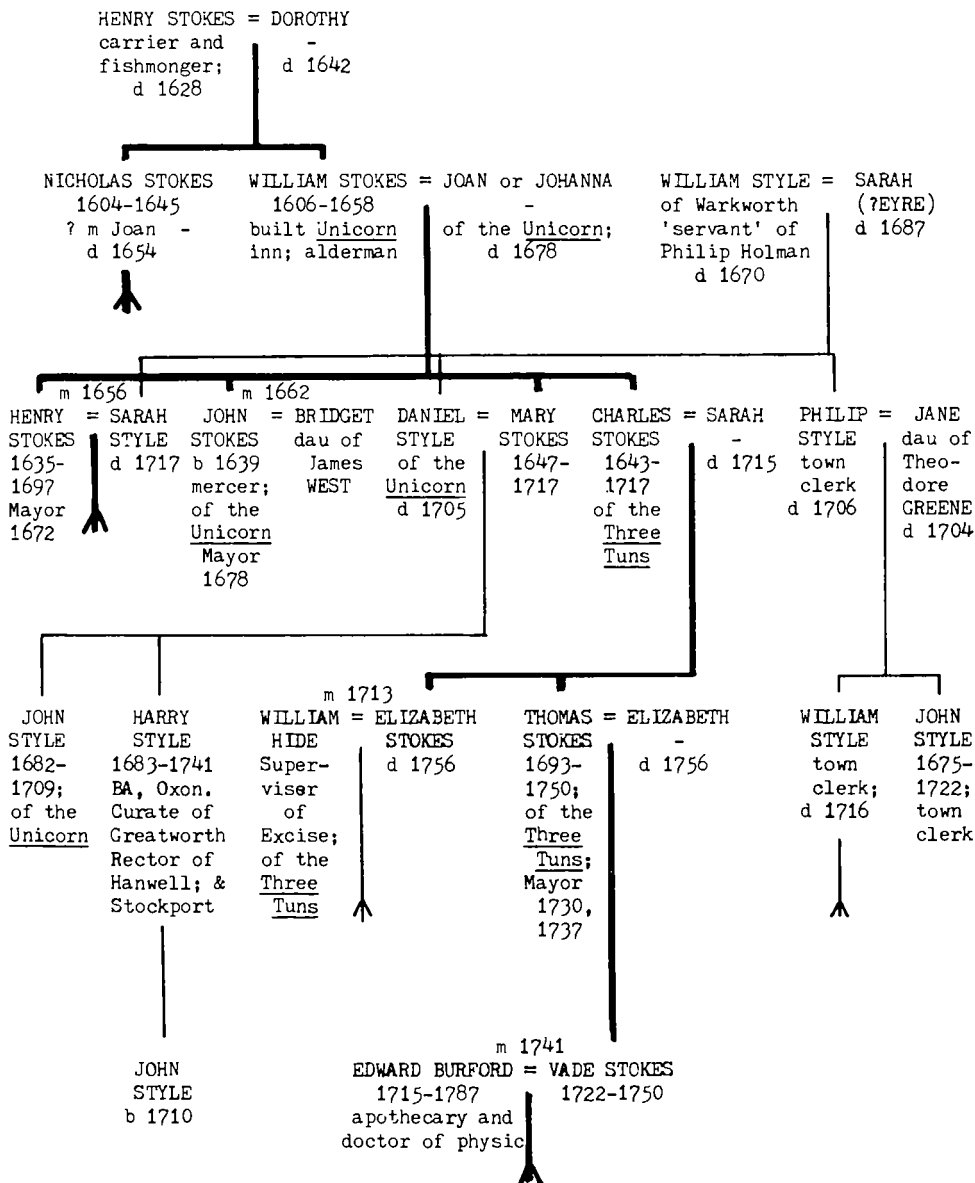

the subsequent lawsuit²¹ were taken in January 1657/8, at the Unicorn itself for the Mayor's supporters. By then Stokes has become an Alderman.

In September 1656 William's second son Henry had married Sarah the daughter of William Style of Warkworth. Style (or Styles as it was frequently spelt) was the equivalent of agent for a local land-owner, Philip Holman of Warkworth Castle.²² The connection between the two families was to be close, as Style's second son, Daniel was to marry Mary, Stokes' second daughter, and eventually become landlord of the Unicorn himself.

Then in June 1658, still in his early 50s, William Stokes died intestate. Money he had lent to the Corporation continued to be repaid for several years afterwards to his widow. Moreover, Joan Stokes continued to run the Unicorn herself, with the help of her family, for the next twenty years. The eldest son, William, appears to have gone to London.²³ In 1661 the second son, Henry Stokes, gave £2, "for himself and his mother", to a "free and voluntary gift" to the recently-restored Charles II; it was one of the more generous contributions (only two of the town's inhabitants gave more).²⁴ But in 1662 and again in 1665 Henry was assessed independently of Joan Stokes for his own home of six hearths, so it does not seem he was by then directly involved in running the tavern. From 1657 on, he progressed through the posts of tithingman, constable and assistant, to become a Burgess in 1666 and Alderman two years later. In 1673-4 he was Mayor. His occupation is unknown; he died in February 1697/8.

A younger son, John (born 1639), certainly was involved in the running of the inn, as appears in his mother's will;²⁵ at that date, January 1677/8, although he was a mercer,²⁶ the Unicorn was described as being in his occupation. In 1662 he had married Bridget, daughter of James West, yet another Banbury mercer, an Alderman who had been Mayor in 1657-8.²⁷

In compiling the Hearth Tax returns of 1662 and 1665 the enumerators clearly used different methods, as the two lists of names differ in order greatly - some may have gone from house to house along one side of a street, whilst others crossed to and fro - or different enumerators may have done different sides. But some similar patterns do emerge, and one is that James West's name immediately follows that of Mrs Stokes in 1662 (with six hearths), whilst in 1665 it immediately precedes hers (now with only three hearths).²⁸ In this part of the town, facing on to the Market Place, it would be illogical not to go from one house to the next, so the returns do suggest that James West was neighbour to Joan Stokes, as well as being father-in-law of her son John.

That this was indeed the case is shown by Thomas Robins' will, dated 1665,²⁹ in which he left three properties: "the house where I now live" (unspecified); a house in Beast Market street; and a house "lately built by me situate and being at the south-east end of Parsons Lane now in the occupation of James West."

In 1668 the son of this Thomas Robins, also named Thomas, married Jane Allington, whose brother John was an apothecary who had

come to Banbury a few years earlier.³⁰ Four years later Thomas Robins is found leasing a house "in the Markett Street near the Market Place . . . in the occupation of [John] Allington."³¹ Then in 1676 Robins is evidently selling up - he had moved to London preparatory to emigrating to a "plantation in Merryland [Maryland]". The house is sold to his father-in-law, the wealthy vicar of Leamington Hastings in Warwickshire; and is described as "a messuage, with yard, stable and garden, in the Markett Place, . . . in the occupation of John Allington, apothecary, being a corner house there and next to an Inne commonly called or known by the name of the Unicorne";³² proof positive of the location of the Unicorn and its neighbour on the corner of Parsons Street.³³

* * * *

In November 1666 the Unicorn was the scene of a bizarre incident, when a German physician, Albertus Otto Faber, lodged there with Richard Boulton, Obadiah Gray his servant, and Thomas Purvey. As Elizabeth Bruncker deposed³⁴ later, "between seven and eight of the clock at night there being four strange persons lodged at the Unicorn where she is a servant . . . who being in a room and talking together [she] looking through a hole in a wainscott from the next room saw them and heard them discouraging sometimes aloud and sometimes whispering, and one say 'when we have done our mischief, we will take our horses and ride out, because we should not be thought to have a hand in it, and afterwards will come again, and bemoan their condition, that they may conclude that we have no hand in it.' Then they read a paper, talked of what the rich devils will do when they see fire about their ears, spoke of their bargain, said their charges would be borne, and they would want no money, when in London; also that they should do well if they did their business privately, but should suffer if discovered. They looked out several times to see if anyone hearkened."

This extraordinary story, which was reported to the local Justices, and by them to the Privy Council no less, was doubtless connected, like many other wild rumours, with the Great Fire of London only ten weeks before. The following April Faber was petitioning the Council, saying he had gone, after the plague and the fire, to Banbury to settle his affairs, where he was apprehended, sent to the common gaol and on to the assizes. He was kept twenty weeks in prison awaiting trial for the firing of Banbury, and the Judge spoke of him as a fortune-teller and mountebank of whom the land should be well rid. Henry Stokes and others of Banbury had tried to get the other three released, and Faber only detained; and the gaoler also to increase his livelihood was complaining of ill-conduct in his prisoners. No more is known of this dubious character, but it is intriguing to wonder what affairs he might have had in Banbury or quite what the "plot" that the credulous chambermaid overheard really was.

Joan Stokes made her will on 17 January 1677/8.³⁵ Some time before that her daughter Mary had married Daniel Styles, brother of Henry

Stokes' wife. Although his father William had died in 1670, Daniel continued to live at Warkworth until late 1676, when he leased a house in Beast Market street;³⁶ so by 1677 his mother-in-law could describe him "of Banbury". Confining legacies to her sons to sums of money, and in the cases of Humfry, John and Charles, merely a token 20s. for mourning rings, Joan Stokes divided her estate between her two younger daughters Mary and Susanna, who was unmarried. Her sons Henry and John, described respectively as "gent." and "mercier", were instructed to sell "that messuage or tenement commonly called the Unicorne now or late in the tenure or occupation of the said John Stokes . . . with all convenient speed . . . and in the meantime to let it."³⁷ One of the supervisors of the will was her "loving friend" Philip Styles, the elder brother of Daniel, whose daughter Sarah was a god-child. Philip Styles was then, or shortly became, Town Clerk of Banbury. His father William had left him "all my law books",³⁸ and in 1705 he was living in a house in Sheep Street belonging to his brother Daniel.³⁹ After his death in 1706 he was succeeded in office by his elder son William (died 1716), in turn succeeded by his younger brother John (died 1722).

Joan Stokes also left token 20s. legacies to John Bagstraw, a trustee, and Samuel Tryst junior of Culworth, Esquire. Some time after her death in June 1678 the Unicorn was sold to a John Tryst of Culworth.⁴⁰ This may have been a doctor who died the following year at Tachbrook, the younger brother of the elder Samuel Tryst.⁴¹ Daniel Styles' will made in 1705 was witnessed by Andrew Tryst, a Banbury doctor,⁴² so clearly there were close connections between the two families.

The identity of the landlord of the Unicorn after Joan Stokes' death in 1678 is not certain. From September 1676 the annual grant of the two wine licences are recorded in the Corporation Account book (there are unfortunately no earlier references). In 1676 they were issued to Thomas Sutton (of the Reindeer) and "Mr Stokes", and in 1677 licences were "continued to Mr Sutton and Mr Stokes". One would expect these to refer to John Stokes. However in September 1678 the second licence to sell wine was specifically to "Mr Charles Stokes". This Charles was the youngest (surviving) son of William and Joan, born March 1643/4. By now he would be in his mid-thirties, and as his elder brother John was a mercier, Charles may well have taken over running the Unicorn. John and Charles were also both by this time members of the Corporation, indeed John had been an alderman since 1672 and was actually Mayor in 1678-9, while Charles had become a burgess earlier in 1678. The record of licences was omitted in September 1679, but in 1680 they were again "granted to Mr Thomas Sutton and to Mr Charles Stokes to keep taverns as formerly. etc. (selling good wine and just measure)". In 1681, 1682, 1683 and 1684 the same pair were granted licences "to keep taverns as formerly". In none of these years were the taverns named.

September 1685 saw a change. "A new licence is granted to

Mr Daniel Style. The licence is granted to Mistress Sarah Sutton as formerly" (Thomas Sutton had died in April 1685); whilst in September 1686 licences were "granted to Mr Daniel Styles to keep a tavern at the Unicorn . . . and the like to Mistress Sarah Sutton . . . at the Reindeer."

However in September 1687 came another significant change: the licences were "granted to Mr Charles Stokes to keep a tavern at the Three Tuns . . . and the like to Mistress Sarah Sutton . . . at the Reindeer. This is the first known reference to the Three Tuns, soon to become (if not already) Banbury's leading tavern and to remain so for most of the 18th century. Beesley has referred to it as existing from 1677,⁴³ but this seems to be based on the issue of a wine licence to one of the Stokes family in that year. As has been shown, this probably refers to the Unicorn. The more probable sequence of events was that Charles Stokes continued to be in charge of the Unicorn until 1685, but only as tenant. Then, wanting to own his own business, he acquired the property in the Horsefair now incorporated in the Whately Hall Hotel (itself with a datestone 1652),⁴⁴ and set up a new tavern. The tenancy of the Unicorn was transferred to his brother-in-law Daniel Style, who continued to hold the wine licence whilst Charles Stokes was establishing the Three Tuns.

Professor Alan Everitt, in a paper on "The English Urban Inn, 1560-1760",⁴⁵ offers a wealth of parallels. His examples are mainly from Northampton, which though larger and a county town is in many ways comparable to Banbury. One of the commonest sites for an inn was in the market place, like the Unicorn, but, as he points out, this was not always an ideal site for a large inn once the coaching era had begun. By the late 17th century, and even more so in the 18th, the growth of the coaching and carrying trades meant that "the chief requirement was a long site with room to build extra chambers and warehouses, and a back entrance so that wagons and coaches could enter the yard and leave it without turning and backing - always an awkward problem for a horsedrawn vehicle." Moreover, the growth of important inns was particularly noticeable in "thoroughfare towns", those situated on principal roads. Narrow and tortuous streets might be impracticable for wheeled traffic, and the decline of the Reindeer Inn in Parsons Street can be attributed to this. In consequence inns on the outskirts of towns rose in importance.

In the later 17th century, too, growth in trade made much more ambitious buildings possible. The George in Northampton, rebuilt in 1675 at the cost of £2,000, was described by Defoe as "more like a palace than an inn"; another visitor remarked that the leading inns there were "such gallant and stately structures the like is scarcely elsewhere to be seen." Indeed it is not suggested that the Three Tuns was on this scale. But its site, on the Horsefair, with plenty of space in front, and on the main through route from Oxford to Coventry and Warwick, was, as it remains, ideal. It would moreover fulfil a useful trading function as a rendezvous for those attending the important horse fairs. Further comparison with

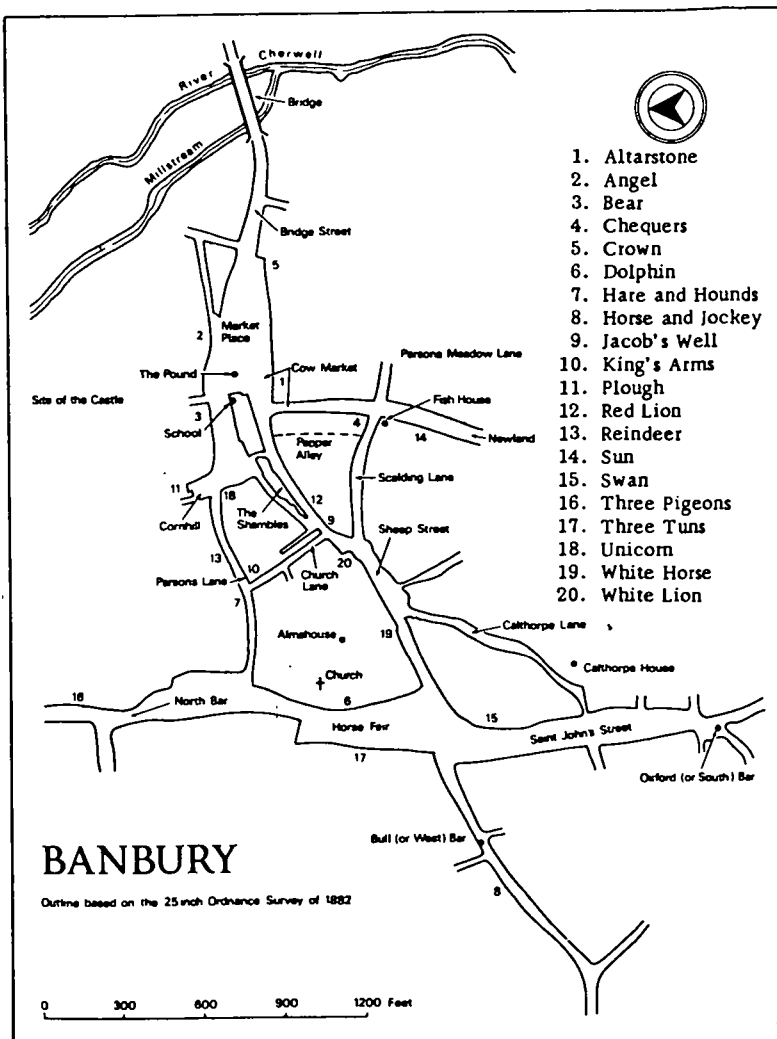

Location of the Unicorn (18) and the Three Tuns (17) in Banbury. Cornhill marks the Barkhill area. The 17th century Dolphin mentioned in note 37 must have been different to the 18th century one in the Horsefair (6).

Northampton must be restricted to the status of the landlords of such inns. There, as in Banbury, they were frequently and for several generations influential members of the corporation, often describing themselves in their wills and elsewhere as "gent." As shown below, Charles Stokes's nephew Harry Style went to the University and became a clergyman. Charles himself, by the time of his death, was clearly a wealthy man.

Another function of these later inns was the provision of an "assembly room". In the 18th century, at least, the "Great Room" at the Three Tuns fulfilled this role.⁴⁶ And it seems that right from the start, Charles Stokes and the Three Tuns were established as the centre for events of consequence, and in no uncertain way - for over the door in one of the upper rooms is painted an inscription



"The Fathers Dyneing Roome September ye 2 ye Kings Progre^s 1687." It was on 2 September 1687 that King James II visited Banbury on his way from Coventry. The "London Gazette" records that he was received with all joy and duty the inhabitants knew how to express, whilst the Wardington parish register contains entries of three parishioners who had been touched for the "King's Evil" (scrofula) at Banbury that day.⁴⁷ The conclusion that the King was entertained at the Three Tuns is inescapable. Ironically the King in Council only two months later ordered the removal from the Corporation of, among others, Charles's brothers Henry and John Stokes, whilst in February 1687/8 Charles himself was ousted.⁴⁸

All were to be reinstated with the rest of the ejected aldermen and burgesses in October 1688, when James II, desperate to save his throne, abrogated the unenrolled charter of 1683 under which the councillors had been expelled, and the former Corporation were restored. But meanwhile, on 29 September 1688, of the two wine licences, one had been renewed to Mrs Sarah Sutton (presumably unpolitical), but the other had gone to Mr John Towerzey at the Red Lion. Was that an establishment of a different political hue? Impossible to decide, as in the following year, with the old Corporation firmly re-established the "wine licences were granted to Mr Charles Stoakes and Mr John Towerzey to keep taverns at their several houses they now live in." Maybe it was just that the Reindeer was going downhill! Anyway, in 1690, 1692 and 1693 (no reference in 1691) the licences went to Charles Stokes and Daniel Style, so evidently the Red Lion did not find favour for long. Thereafter the record ceases.

Daniel Style remained landlord of the Unicorn until his death in 1705. Ten years earlier there occurred an incident that just might reflect on the inn's falling reputation. Mary Mole, an unmarried Cropredy girl,

deposed⁴⁹ "that of Thursday before Easter . . . being at Banbury in the afternoon she went to the house of Henry Lucas being the sign of the Cock . . . where she met with John Haslewood and William Toms both of Cropredy; and then and there John Haslewood asked her to drink but she replied she would not drink with him upon which they parted. Some time after in the same day she met John Haslewood at the Unicorn Gate . . . and here he did ask her to drink with his wife and his sister and the said Toms which were gone into Ed. Pinor's as he told her; and she consented to it and immediately Haslewood and she went into an upper room over the staircase, and he called for a bottle of sack and a cake which were brought up accordingly by a servant maid; and upon the maid's departure Haslewood locked the door, which she asked what he meant by it, and then he replied he would have his will on her. But she replied she was not willing to consent, thereupon he swore he would have the use of her body and laid hands upon her and thrust her to the wall, and had then and there twice carnal knowledge of her body within half an hour or thereabouts, and that hour he the said Haslewood got her with child of a bastard child which was born about St. Thomas' day last past, and that no other person had ever any carnal knowledge of her body." A sad and sordid little story, and bearing in mind how easy it was to hear through the Unicorn's interior walls, Mary Mole can't have made much protest! At any rate, when the case came to the Oxford Quarter Sessions John Haslewood, an apparently respectable yeoman, "did utterly deny the fact" and claimed "that the same child was begotten by some other person, she having confessed the same to the midwife when she was in travail and in her extremity before she was delivered and since the delivery of the said child." Such was the callous method of identifying fathers of bastard children. The verdict was that Mary Mole was sent to the house of correction for incontinency.

On his death, Daniel Style was evidently succeeded by his elder son John. The Unicorn is mentioned as their home both at Mary Styles's marriage later in 1705, and at John's own burial after his early death in 1709. The younger son, Harry, was, in his father's will, "to be kept at the University of Oxford for 3 or 4 years."⁵⁰ In fact Harry Style took his B.A. the following year, and in 1710 was Curate at nearby Greatworth, when his son was baptised at Banbury. He was subsequently Rector of Hanwell, 1712-1717, and then of Stockport in Cheshire until his death in 1741/2.⁵¹ But with John Style's death the family connection with the Unicorn came to an end.⁵²

The later history of the Three Tuns, under Charles Stokes and his son Thomas, and their successors, will be the subject of a further article.

J. S. W. Gibson

References

1. Hearth Tax, 1662. P.R.O. E.179/255/4/Part 3, f.263 (Constables' Returns).
2. Hearth Tax, 1665. P.R.O. E.179/164/514. This was the first, rough, copy, from which a fair copy, E.179/164/513, was made. The latter, though perhaps easier to read, embodies a number of mistakes, for instance Joan Stokes' name is mistranscribed "Stocke"; unfortunately it was from the fair copy that the transcript printed in Oxon. Record Soc. vol.21 (1940) was made. The Banbury section is on pp.156-60, with the parish outside the borough on p.154.
3. On 28 March 1761 an advertisement appeared in "Jackson's Oxford Journal" (no.413, p.iii) for the former Unicorn Inn to let, now proposed for tradesmen's houses; in midst of Market Place. In 1839 the range fronting the Market Place was described as formerly used with the Unicorn Inn, Oxon.R.O., Aplin Hunt collection, 27/1.
4. Baptism and Burial Register of Banbury, part 1, 1558-1653, Banbury Hist. Soc., vol.7, 1965-6. References to dates of birth, baptism, marriage, death and burial are unless otherwise stated from this and its succeeding volume, part 2, 1653-1723, vol.9, 1968, later unpublished registers, and the accompanying volumes of marriages, 1558-1723, vol.2, 1960 and 1723-1790, vol.3, 1961. Henry Stokes' will was proved in the Prerogative Court of Canterbury (P.C.C.), 1629:33.
5. Corporation records, Tudor and Stuart - edition in preparation, to be published as Banbury Hist. Soc., vol.15. This is arranged chronologically, and all references to corporation affairs should be easily identifiable.
6. Banbury Wills and Inventories, Part 2, 1621-1650, B.H.S. vol.14, 1976, nos.348, 376.
7. Bodleian Library, MS Charters Northants. c.30(5); the name of Stokes' inn is not stated and is unknown. I am grateful to Dr D.M. Barratt for bringing this reference to my attention.
8. See "Cake & Cockhorse", vol.6, no.5 (Spring 1976), pp.83-86, J.S.W. Gibson, 'A Disputed Inheritance'.
9. Lay Subsidy Rolls, 1642-3. P.R.O. E.179/164/481 and E.179/164/508; whilst for that of 31 May 18 Charles I, E.179/164/493, when 287 of the town's taxpayers are listed, only three are higher assessed.
10. 7 Edward VI c.5 (1553); "History of Liquor Licensing in England", S. and B. Webb, 1903, pp.22-25.
11. Will of John Hall, P.C.C. 1646:162.
12. Banbury Wills and Inventories, Part 1, 1591-1620, B.H.S. vol.13, 1976-7, no.193; Bodl. MS Charters Oxon. 3586, 1674.
13. "Cake & Cockhorse", vol.2, no.10 (Nov.1964), pp.159-63, Michael Laithwaite, 'The Reindeer Inn'.
14. Victoria County History, Oxon., vol.10, Banbury Hundred, 1972, p.33.
15. J.G. Milne, "Catalogue of Oxfordshire 17th Century Trade Tokens", 1935, p.32.
16. "Cake & Cockhorse", vol.1, no.9 (Sept.1961), C.F.C. Beeson, '17th Century Inn-keepers in Banbury', pp.124-5.
17. Bodl. MS Ch.Oxon. 3576; John Bentley's will, P.C.C. 1646:138 (but dated 1643), gives no location for the house.
18. Beesley, "History of Banbury", 1842, p.275; the map of streets in medieval Banbury given by Potts, "History of Banbury", 1958, facing p.98, shows Barkhill as a restricted part of the north side of the Market Place; but the more authoritative Paul Harvey, in "Historic Towns: Banbury", ed. M.D. Lobel, 1969, shows it covering all Cornhill; Dr Harvey also discusses its location in "Oxoniensta" 31, 1966, in 'Where Was Banbury Cross?', pp.91-92.
19. Bodl. MS Ch.Oxon. 3577.
20. This can only be put forward as a possibility, as the site of Thomas Robins' own home as referred to in his will, below, is unknown, and might well have been on the north side of the Market Place, the traditional location of Barkhill; whilst the description

and dimensions of site suit that equally well (before the curve of the houses north into the modern Cornhill); and it seems surprising that a property stretching up Parsons Street in the way it does is not so described. This Parsons Street frontage, the north side of the property, only measures 67 ft., but the south side, backing on to what became the Unicorn, might have been of much greater length. The Unicorn yard, from the Market Place, is about 120 ft.

21. "Cake & Cockhorse", vol. 7, no. 2 (Spring 1977), J.S.W. Gibson, 'Trouble over Sheep Pens', p. 43.
22. Will of Philip Holman of Warkworth, P. C. C. 1669:86; William Style had himself lived, or at least owned property, in Banbury - Bodl. MS D.D. Risley A VI 4/3.
23. Mr William Stoakes, "of London", was buried at Banbury, 27 Jan 1673/4.
24. P. R. O. E/179/255/5.
25. Will of Joan Stokes, P. C. C. 1680:30.
26. Bodl. MS Ch. Oxon. 3585, 1673; and so described in Joan Stokes' will, 1677.
27. Cropredy marriage register; will of James West, P. C. C. 1684:132. Bridget West's mother was sister of John Bentley from whose widow Williak Stokes had bought land in 1647.
28. Hearth Tax returns, 1662 and 1665 - see refs. 1 and 2.
29. Will of Thomas Robins, P. C. C. 1668-70.
30. Banbury Corporation records. John Allington was appointed a Tithingman in 1664.
31. Bodl. MS Ch. Oxon. 3583; 3584.
32. Bodl. MS Ch. Oxon. 3587; "Warwickshire History", vol. 3, no. 3 (Summer 1976), James Salter, 'Wills and Inventories of Warwickshire Clergy, 1660-1720', p. 87; and I am grateful to Dr Salter for further information on the Reverend John Allington; his will, P. C. C. 1683:52, in which he mentions "Jane wife of Thomas Robins supposed to be on his plantation in Merryland".
33. Curiously, and confusingly, the title deeds of the building known as the Original Cake Shop (12 Parsons Street, now demolished) imply that that too was known as the Unicorn in 1666 (V. C. H. , 10, p. 31) - but from the Hearth Tax returns, when it was occupied by Edward Welchman, we know that he had only four hearths, and it can never have been an establishment of any size or importance.
34. P. R. O. , State Papers Domestic, 21 Nov 1666 (vol. 178, item 168), 2 and 3 April 1667.
35. Will of Joan Stokes, P. C. C. 1680:30.
36. Bodl. MS Ch. Oxon. 3588.
37. Joan Stokes had owned other property in Banbury - she had at some stage sold the Dolphin Inn "in Brechle Street near the Market Place" to the Hams family, Oxon. R. O. , Aplin Hunt collection 20/A, deed dated 1711.
38. Will of William Style, P. C. C. 1671:28.
39. Will of Daniel Style, P. C. C. 1705:219.
40. V. C. H. Oxon. , 10, p. 33.
41. George Baker, "The History and Antiquities of the County of Northampton", vol. 1, 1822-30, pp. 752-3, pedigree of Trist or Tryst of Culworth.
42. Will of Daniel Style, P. C. C. 1705:219; Andrew Tryst, doctor of Banbury, was party to a deed in January 1716/7, Bodl. MS D.D. Risley A. VIII 3/2.
43. Beesley, "History of Banbury", p. 504.
44. V. C. H. Oxon. , 10, p. 29, fn. 2.
45. Alan Everitt, ed. , "Perspectives in English Urban History" (Problems in Focus series), 1973, 'The English Urban Inn, 1560-1760', pp. 91-137.
46. Potts, "History of Banbury", p. 183.
47. Potts, pp. 165-6; Beesley, p. 503.
48. P. R. O. , Privy Council Registers, 2/72, pp. 534-5; 590.
49. Oxon. R. O. , Quarter Sessions Rolls, 25 June 7 William III.
50. Will of Daniel Style, P. C. C. 1705:219.
51. H. I. Longden, "Northamptonshire and Rutland Clergy", under Harry Style.
52. For the subsequent history of the Unicorn, see V. C. H. Oxon. 10, p. 33.

MRS. FRANCES ANN BOWKETT
A BANBURY SCHOOLMISTRESS AT THE TURN OF THE CENTURY

It is difficult for anyone meeting Mrs. Frances Ann Bowkett of Banbury for the first time - as I did on 29 March, 1977 - to realize that she began her teaching career in the town before the turn of the century. For although her sight is now failing, the vigour and alertness she displays belie her 102 years.

Frances Bowkett (née Goodway) was born on 30 November, 1874, the daughter of a coachbuilder and painter of Gatteridge Street. As a small child, 'not five years old', she attended the Britannia British Infants' School in Cherwell Street, which had been opened in 1861 thanks to the interest and financial support of Bernhard (later Sir Bernhard) Samuelson. From there she moved into the senior mixed department, where the children were all taught in one big room, with curtained partitions to divide off the different classes, or standards. Needless to say, given the large number of scholars of various ages in attendance, the youngsters 'were not allowed to make a noise'.

Eventually at the age of fourteen Mrs. Bowkett was accepted as a pupil teacher in that same establishment: 'You had to pass the doctor to become a teacher and then you were apprenticed for four years.' As a condition of apprenticeship, Frances and her fellow pupil teachers were required to receive lessons from the headmaster every day, to supplement their own private study and to prepare them for the annual examinations they had to take during their training period. At the end of this they hoped to pass the Queen's Scholarship examination which permitted them to enter a training college. At Cherwell Street the head held these lessons each morning from twenty minutes to eight until twenty minutes to nine, which meant a very early start for the apprentices: 'And then we started teaching. We had a class of fifty to sixty children or more.' Frances herself - at the ripe age of fourteen - was expected to teach the third standard (i.e. children of about nine years of age), whom she remembers taking for English geography: 'You had to teach what the different towns manufactured. We used to stick a bit of cloth on where it was Bradford, and a bit of carpet for carpet-making areas, and pin them in the map. We used to have a huge map of England. Then they learnt history a bit; we didn't go in for history so much as geography. We also used to learn about the villages around.'

When the training period had been completed, 'I went to Stockwell College in London and then I came back to Banbury when I was twenty-three.' In fact Mrs. Bowkett remained in the firmly disciplined atmosphere of Stockwell for two years - one of over 150 students. In 1895 (when she was still at the college), H.M.I. Oakeley commented somewhat ominously vis-à-vis its daily round: 'As there is no doubt that the students work hard, it is satisfactory to find that the medical officer states, "There



Frances A. Bowkett (née Goodway)
graduating as a teacher from
Stockwell College London in the mid-1890s.

is nothing in the college course that should prejudice the mental or physical condition of a student who enters in good health . . . '1 But at least conditions had eased compared to the position in the early 1870s, when the regulations had carefully laid down:

'The Ladies' Committee wish it to be distinctly understood by all candidates for admission that they consider neatness and plainness of dress incumbent on those who undertake the instruction and training of the young; and it is the express wish of the committee that no flower, ornament, or other finery should be worn. '2

On leaving Stockwell, Frances taught for about two years in London before moving to her home town in 1898, to take up the headship of the Cherwell Infants' School - where her own scholastic career had begun. At that time there were about 180 scholars on the register and there were three assistant teachers. She was to remain head of the school for the next thirty years.

Both as a pupil teacher and a college student, Mrs. Bowkett had been trained 'for classes for children from seven to fourteen', so when she undertook the teaching of infants she quickly became impatient at the dull, repetitive approach to instruction then in vogue. This was particularly the case in teaching children to read, when they were required to recite endlessly such phrases as CAT spells cat, MAT spells mat, and so on: 'I didn't hold with that'. Instead she developed her own phonic method of teaching reading, based on principles similar to shorthand, but with the major proviso of seeking to attract and hold the children's interest. For as she herself wrote at about this time: 'The secret of success in any subject is the happiness which attends it. '3

As a first step the children had to learn their letters and this they achieved with the aid of special games, which would 'direct the child's observation to the form of the letter or to the nature of its sound . . . The game is the thing, the success of it depending on the personality and sympathy of the teacher and her ability to become a little child. The little ones have found the same pleasure in these letter games as in any other game. They like to personate a letter and talk as a letter talks just as much as they like to personate and to imitate the sounds of animals'. To this end, therefore, Mrs. Bowkett and her assistant, Miss M. Shrimplin, produced a series of rhymes based on the letters of the alphabet, which were designed to appeal to even the youngest pupils - aged three years of age. Thus for letter 'a':

Here is letter "a"
Looking stout and fat,
His head is hanging down so low
He cannot wear a hat.

The teacher would recite the rhyme, draw a letter 'a' on the blackboard and direct the attention of the pupils to its shape. 'Then all the children

don hats. One child personates "a" and wears a giant "a" round his neck. They go for a walk, the children's hats keep on, but "a's" hat continually drops off the evident enjoyment of all. ' Similarly with letter "b":

Here is letter "b"

He is very kind,
The tiny letters ride to school
On his big back you'll find.

'Children personate any letter, teacher is "b" and gives another child letter a ride on her back; "b" is drawn on blackboard with little letter on its back'. And so it went on through the alphabet.

So successful were Mrs. Bowkett's methods that she was asked by the Oxfordshire Education Committee to give Saturday morning lectures to infants' mistress from nearby villages - 'about twenty-three used to come'. To her, reading was all-important: 'I always thought what a dreadful thing if a child couldn't read. Life was closed to them.'

This concern for innovation was not, however, confined to reading. As she recalls: 'I was very keen on entertainment because I always felt that entertainment was a stimulus to the children'. So school plays were organized. She and her fellow teachers worked many hours to make the children's costumes for such presentations as *Cinderella*: 'I tried to get every child in. They had something even if it was a minor part.' When all was ready the general public were invited to attend, and their admission fees helped towards the financing of a pupils' boot fund. Without such aid some of the children 'couldn't have come to school' as they had no shoes. But 'we generally gave so much to the trustees of the Hospital and the Nursing Association' in Banbury as well. At Christmas a mother's party was also held at the school and all of the children made a small gift for their mother. While at the annual prize-giving - as in 1911 - 'The children presented a bright and attractive appearance, and entertained the visitors to songs and drills', according to the *Banbury Guardian*. And the paper added: 'The children are particularly well disciplined, which reflects great credit on the school staff'.⁴

But one of Mrs. Bowkett's abiding memories of Cherwell school at the turn of the century is of the poverty of some of the families. So although attendance was normally good there were sometimes problems on Thursdays - the market day - 'when the cattle were in the roads in Cow Fair and the horses were in the Horse Fair. Some of the children would go and mind the calves. The parents were so poor and the children got a few coppers minding the calves'.

Outside the school her interest in 'entertainment' was also sustained. Perhaps her biggest venture in this direction was the organizing of the town's pageant to celebrate the King's Coronation in June 1911. 'At that time pageants were the great thing. Banbury couldn't be left behind', so *St. George for Merrie England* was duly set in hand. Costumes had to be made and rehearsals planned, but in the end it was a great success.

Indeed, according to the **Banbury Guardian** of 22 June, 1911, 'in consequence of several requests that opportunities of seeing the pageant should be given to those unable to be present on Saturday', two repeat performances were to be given. Mrs. Bowkett herself was presented with a gold bracelet by the performers and others 'as a token of their esteem'.

But, however pleasant, these were only sidelines to the important business of teaching and perhaps the best summary of Mrs. Bowkett's philosophy to this is provided by her closing words to me at our interview: 'The great thing we always impressed was Character. You must try and impress the children to be honest and upright and truthful. It was Character; in all we did we had to keep that in mind.'

Perhaps some readers of this short article will have their own memories of Mrs. Bowkett and of life at Cherwell Infants' School in the early twentieth century.

Pamela Horn

FOOTNOTES

1. **Report of the Committee of Council on Education**, Parliamentary Papers 1896, Vol. XXVI, 220.
2. Lois Deacon and Terry Coleman, **Providence and Mr. Hardy**, London 1966, 35.
3. From Frances A. Bowkett, **Reading and Writing Made Interesting**, n.d. typescript in Mrs. Bowkett's possession, 3. The subsequent quotations on letter games, etc. are taken from the same source. The typescript was produced in the early years of the present century.
4. **Banbury Guardian**, 20 July, 1911.

UNPUBLISHED NOTES ON HEYTHROP HOUSE AND KIRTLINGTON PARK

On the occasions of the last two Annual General Meetings of the Banbury Historical Society, I was able to give to Mr Peter Buxton, the owner of Kirtlington Park and to Mr S.R. Jackson, the Bursar of Heythrop College some brief notes on the houses made in the first half of the eighteenth century. They were written by John Loveday of Caversham (as he is usually known) who was born in 1711 and died in 1789.

At the time of his visit to Heythrop he was at Magdalen College, Oxford and on 29th June, 1734, he rode up to Edgehill with a friend, stopping to see three country houses on the way - Ditchley, Kiddington, and Heythrop. The house belonged at that time to Gilbert Talbot, 13th Earl of Shrewsbury, but he was a Jesuit priest and never lived there. Nor did he assume the title, although he held it. This was probably why the house was closed and John Loveday was unable to see inside. In spite of two fires in later years, the house was restored so well that the facade must look much as it did when he described it, though the adjacent walls have gone and new wings have been added. The Park itself is still very beautiful.

"Haythorp, the Earl of Shrewsbury's, stands in a pleasant Park; it is reckoned to have as elegant a front as most houses. It is built of Stone and by the look of it it cannot be many years since. There are 11 Windows in the front, which is adorned with Corinthian Pilasters and the Portico upheld by 4 easy light Pillars of the same Order; the Building is not high, it is much ornamented, even to the very Chimnies. A Ballustrade of Stone on the top of the house. In the same Line with the front and on each side of it, runs a Wall which has four openings in it, discovering a very large View of the adjacent Country towards Enstone - for the house stands very high on the edge of an hill. The Beauty of these Openings is when you approach to the front through the Park; there you have in view the most elegant Work of Art and at the same time view Nature in great Variety, each adorning the other. But to this open Wall there joins at right Angles (on each side also) another Wall of the same height and Length with the open Wall, but it is closed, yet has four blind openings in it; from this Wall (on each side) in a line are the Stables, built in a rougher Stile, but proper to the occasion."

Some twelve years later, on 15th July, 1747, he rode over to Kirtlington Park from Arlescote, near Edgehill, where he was staying with his brother-in-law, William Goodwin. He was interested in new buildings as well as older ones and this great house had only been completed for Sir James Dashwood the previous year. His notes, unfortunately, were very brief but they produce the only evidence that the staircases were made of Norwegian oak.

"July 25th, 1747. Kirtlington Park, Sir James Dashwood's. This magnificent house is so spacious as to contain fourteen Lodging-Rooms on a floor with a Dressing-Room to each. The Stair-Cases have Sky-Lights only. The floors are of Norway Oak: the Garrets have floors of Stucho. The Offices are truly noble. But, after all, the place is but ill supplied with Water, that upon the spot being very hard indeed."

Sarah Markham

D. W. Harrington, **'The Egerton family of Adstock in the county of Buckingham'**, **Family History**, Vol. 9, Nos. 53/56 (November 1975), pp. 93-128 + 4 plates. £1.50.

The Revd. P. R. Egerton was one of Bishop Samuel Wilberforce's 'Cuddesdon curates' appointed to Deddington in 1859 during the absence of the notorious vicar, the Revd. James Brogden. When the vicar announced his return, Egerton had to look for another post, and by coincidence the school at Bloxham, empty since the Revd. J. W. Hewett's bankruptcy in

1857, came up for sale. Encouraged by one of his fellow-curates Egerton bought the buildings and turned schoolmaster. Thereafter, although he continued to take services at Hempton for a time, Egerton's interests centred on his school, a familiar landmark of the neighbourhood.

Duncan Harrington is an Old Boy of the school and has carried out meticulous and well-documented research into the ancestry of Reginald Egerton's family, prompted by controversy about the school coat of arms. The school displays the arms of the Egerton family, sable a chevron between three pheons argent, but Reginald Egerton's right to the arms had never been established. Mr. Harrington successfully proves Egerton's armigerous claim.

For local historians unconcerned with the minute detail of the Egerton pedigree the article nevertheless provides some new evidence about the origins of Bloxham School and provokes further questions. A considerable capital outlay is required to start a school. Some of the money for developing Bloxham came from Egerton's private resources, now seen to be derived from a long line of merchants and citizens of London, although the size of his fortune and the terms of his father's will are not revealed to us. The other chief source of finance was his wife's family. From **The Letter-books of Samuel Wilberforce** (Oxfordshire Record Society, 1970) we learn that his wife, Harriet Gould, was his cousin. Mr. Harrington records that his mother was a Gould, and it would now be useful to explore the Gould pedigree and background.

Brian S. Smith

R. E. Sherwood. **Civil Strife in the Midlands 1642-1651**. Phillimore 1974 pp. 264. £4.25.

Very often the English Civil Wars are telescoped into the battles of Edgehill, Marston Moor, and Naseby, thus giving the impression that these were the only events in the nine years of turmoil from 1642 until 1651. This is a pity, because the general character of the Civil Wars was one of siege and counter-siege, organised or disorganised raids, and personal battles which were really continuations of old family feuds. In fact the strategy leading up to the major battles was often dictated by the prevailing local conditions.

Mr Sherwood's book attempts to trace these fascinating local turns of fortune by giving an account of the Civil Wars as they affected the Midlands. Events happening outside this area are also given so that a continuous narrative is provided. It is neither a political history, nor a detailed military history, but a general picture of what the wars meant to the harassed Midlanders.

So we are told of the utter disruption of trade between the Royalist garrison towns and Parliamentary London, of unfortunate villages like Bredon which had to pay taxes to both King and Parliament, and of towns

paying tribute to one army being raided by the other (quite apart from being raided by their own garrison). There is the sad story of Thomas Green, robbed of his saddle by Parliamentarians and then arrested for theft by Royalists because he was riding a horse without a saddle.

Of special interest to us is the description of the Royalist capital of Oxford, and the discomfort and disruption it caused in that city, and the fourteen week siege of Banbury Castle in 1644 which included artillery bombardment, mining operations, and no fewer than eleven direct assaults. Even so it held out until relieved by the King's forces, and only surrendered on May 9 1646 when the King's cause was already lost.

This book has neither the detail nor the depth to be a standard work of reference on its subject (and I doubt if many people would leave Grimsbury and march southwards to get to Daventry, as the King's army is said to have done before Cropredy Bridge). One is left, however, with a picture of what life was like for garrisons, their commanders, and the civilian population as the major armies marched and counter-marched through their area. What is more, it is a very entertaining read.

David Smith

Railway History in Pictures: Chilterns and Cotswolds by R. Davies and M.D. Grant. David and Charles 1977. £3.95. 96 pp.

No one under twenty-five has travelled from Banbury (Merton Street) via Cockley Brake, Towcester and Blisworth to Northampton, or from Banbury (General) via Chipping Norton, Kingham and Bourton-on-the-Water to Cheltenham, and memories of cattle being unloaded for the market from railway waggons, of the perpetual cloud of smoke over the engine sheds, or of coal waggons being shunted into the gas works must now be growing dim. For future generations much of the railway system created by the Victorians will be just earthworks and cropmarks, like deserted medieval villages or prehistoric trackways. Collections of photographs are perhaps the best means of adding life to the bare bones of archaeological remains. Railway photographers have always been enchanted by the steam locomotive however, and like all such collections, this book shows relatively little of other aspects of the workings of railways. The authors are not to be blamed, for the photographs just do not exist.

The main criticism of this volume must be the sheer size of the region which it attempts to cover, which ranges from the 'throats' of the London termini to Bath in one direction and to Peterborough in the other, and all of the territory in between. It is difficult to avoid the conclusion that a book devoted to a more concentrated region could have made its points more forcibly. The captions seem designed for railway enthusiasts not for historians, and sometimes the cloying nostalgia comes close to factual error. To whom was the service on the Banbury-Cheltenham route "useful"? Inevitably some more straightforward errors of fact have

crept in. The train from Ardley shown on p.43 is not, whatever may be stencilled on the sides of the waggons, conveying iron ore, but is taking limestone to the Harbury cement works. The 16.34 semi-fast from Paddington shown on p.41 terminated not at Wolverhampton but at Banbury.

Although the book can be faulted in some respects, the authors deserve to be congratulated on compiling a well-balanced and interesting collection of photographs which do give a vivid picture of the railways of the south Midlands in this century. Many of the pictures have real historical as well as purely railway interest, and some are works of high artistic quality. Particularly to be commended are a beautifully lit shot of a Great Northern Atlantic at the south end of Oxford station in 1936, and a scene at Oxford (Rewley Road) in 1914 which is a perfect period piece. There are illustrations of both of the original stations at Banbury, the GWR structure shown in a picture taken in 1935, and Merton Street, shown on the last day of operation of the Blisworth service in 1952. There is a superb view of Brackley (Central) on the day the Great Central London Extension was opened in 1899, and a shot of the Bicester slip coach off the 5.10 p. m. from Paddington being picked by the locomotive of a semi-fast, which recalls a service by which many Banburians enjoyed returning home from the capital.

Many people will be able to remember many of the scenes shown in this collection, but anyone with an interest in local history is recommended to buy it nevertheless. The photographs of the 1950s will, in a quarter of a century, seem as other-worldly as the few shots of the Edwardian era do now.

B. S. T.

BANBURY CHURCH RECORDS

In the September 1964 issue of "Cake and Cockhorse" (Vol. 2, No. 9, pp.154-56), Barrie Trinder listed various church records which the then Vicar of Banbury, the Revd. D.I.T. Eastman, had deposited, on the Society's advice, partially in the Bodleian Library (the Diocesan Record Office) and partially in Banbury Public Library.

Recently the present Vicar, the Revd. Ian Beacham, decided that it would be more appropriate for all these records to be in one place. Accordingly, with the help of the Society, the records formerly in the Banbury Library have been transferred to join the parish registers in the Bodleian.

The records transferred consist mainly of Parish Ratebooks for the period 1782 to 1860; a map of Banbury in 1838, which was printed in "Cake and Cockhorse" when the list was published; and visiting plans, c. 1850, of which use was made by Barrie Trinder in his article "Banbury's Poor in 1850" (C&CH, vol.3, no.6, Winter 1966).

The opportunity has been taken to transcribe the earliest Parish Ratebook, for 1782, and we hope to publish this shortly.

BANBURY HISTORICAL SOCIETY

The Society was founded in 1957 to encourage interest in the history of the town of Banbury and neighbouring parts of Oxfordshire, Northamptonshire and Warwickshire.

The Magazine **Cake & Cockhorse** is issued to members three times a year. This includes illustrated articles based on original local historical research, as well as recording the Society's activities. Publications include **Old Banbury - a short popular history** by E. R. C. Brinkworth (2nd edition), **New Light on Banbury's Crosses, Roman Banburyshire, Banbury's Poor in 1850, Banbury Castle - a summary of excavations in 1972, The Building and Furnishing of St Mary's Church, Banbury, and Sanderson Miller of Radway and his work at Wroxton**, and a pamphlet **History of Banbury Cross**.

The Society also publishes records volumes. These have included **Clockmaking in Oxfordshire, 1400-1850; South Newington Churchwardens' Accounts 1553-1684; Banbury Marriage Register, 1558-1837 (3 parts) and Baptism and Burial Register, 1558-1723 (2 parts); A Victorian M. P. and his Constituents: The Correspondence of H. W. Tancred, 1841-1850; a new edition of Shoemaker's Window; Wigginton Constables' Books, 1691-1836; and Bodicote Parish Accounts, 1700-1822. Part 2 of Banbury Wills and Inventories, 1591-1650, was published in June 1976, and Part 1 is well advanced.**

Meetings are held during the autumn and winter, normally at 7.30 pm. Talks on general and local archaeological, historical and architectural subjects are given by invited lecturers. In the summer, excursions to local country houses and churches are arranged. Archaeological excavations and special exhibitions are arranged from time to time.

Membership of the society is open to all, no proposer or seconder being needed. The annual subscription is £4.50 including any records volumes published, or £3.00 if these are excluded.

Application forms can be obtained from the Hon. Membership Secretary.

Printed by: Parchment (Oxford) Limited, 60 Hurst Street, Oxford, for the Banbury Historical Society.

All articles in this publication are strictly copyright.

